

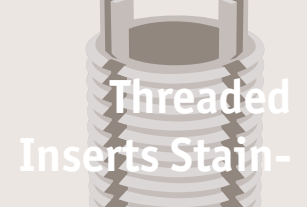

Threaded Insert MS/NAS - Extra H

303 stainless steel - self-locking - MS/NAS grade



Threaded Inserts Stain-

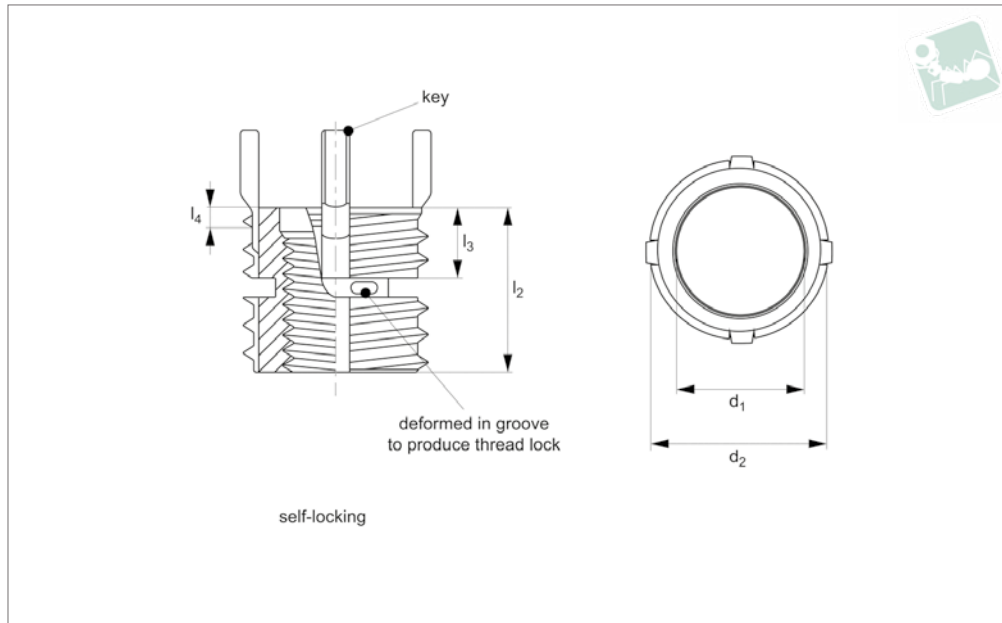

TR1657

THREADED INSERTS STAINLESS

Material

Inserts - 303 CRES.
 Keys - 302 CRES.
 Passivated. Dry film lubrication on self-locking inserts only.

Technical Notes

All dimensions in inches.
 Internal threads: to SAE AS8879.
 General tolerances -
 +/- 0,010 unless specified.
 Tap drill hole tolerances -

0,234 to 0,500 = +0,004/-0,001
 0,500 and over = +0,005/-0,001
SL = Self-Locking type, deliberate deformity in thread produces self-affect once installed (see technical diagram).

Tips

Order installation tool separately, as identified by „Inst. Tool ref.“ in table.

Important Notes

Four locking keys on internal threads 1/4

and over. Two locking keys on internal threads smaller than 1/4.
 Installation (Inst.) drill size, counter sink, thread tap and thread depth as specified in table.
 Removal (Rem.) drill size and drill depth as specified in table.
 Perform to standards: MIL-I-45914A (MS51832)

Order No.	Type	d ₁ tol. 3B	Thread type d ₁	d ₂ (mod.) class 2A	Thread type d ₂	l ₁	l ₃ ±0.030
TR1657.77333	SL	10-24	UNC	7/16-14	UNC	,312	,22
TR1657.77533	SL	10-32	UNF	7/16-14	UNC	,312	,22
TR1657.77334	SL	1/4-20	UNC	1/2-13	UNC	,375	,22
TR1657.77534	SL	1/4-28	UNF	1/2-13	UNC	,375	,22
TR1657.77335	SL	5/16-18	UNC	9/16-12	UNC	,437	,22
TR1657.77535	SL	5/16-24	UNF	9/16-12	UNC	,437	,22
TR1657.77336	SL	3/8-16	UNC	5/8-11	UNC	,500	,25
TR1657.77536	SL	3/8-24	UNF	5/8-11	UNC	,500	,25
TR1657.77337	SL	7/16-14	UNC	11/16-11NS	UNS	,625	,28
TR1657.77537	SL	7/16-20	UNF	11/16-11NS	UNS	,625	,28
TR1657.77338	SL	1/2-13	UNC	13/16-16	UNF	,688	,28
TR1657.77538	SL	1/2-20	UNF	13/16-16	UNF	,688	,28
TR1657.77339	SL	9/16-12	UNC	7/8-14	UNF	,812	,32
TR1657.77539	SL	9/16-18	UNF	7/8-14	UNF	,812	,32
TR1657.77340	SL	5/8-11	UNC	1-12	UNF	,875	,33
TR1657.77540	SL	5/8-18	UNF	1-12	UNF	,875	,33
TR1657.77341	SL	3/4-10	UNC	1-1/4-12	UNF	1.250	,49
TR1657.77541	SL	3/4-16	UNF	1-1/4-12	UNF	1.250	,49
TR1657.77342	SL	7/8-9	UNC	1-3/8-12	UNF	1.375	,49
TR1657.77542	SL	7/8-14	UNF	1-3/8-12	UNF	1.375	,49
TR1657.77343	SL	1-8	UNC	1-1/2-12	UNF	1.500	,55
TR1657.77543	SL	1-12	UNF	1-1/2-12	UNF	1.500	,55



Order No.	1/4 c'bore depth	Inst. c'sink hole size +0.010 -0.000	Inst. tap drill size	Inst. thread tap depth min.	Inst. thread tap size class 2B	Inst. tool ref. TR1706	Removal drill size	Removal drill depth
TR1657.77333	,07	,447	,397	,37	7/16-14	.0330	11/32	3/16
TR1657.77533	,07	,447	,397	,37	7/16-14	.0331	11/32	3/16
TR1657.77334	,07	,510	,453	,44	1/2-13	.0340	13/32	3/16
TR1657.77534	,07	,510	,453	,44	1/2-13	.0341	13/32	3/16
TR1657.77335	,07	,572	,516	,50	9/16-12	.0350	15/32	3/16
TR1657.77535	,07	,572	,516	,50	9/16-12	.0351	15/32	3/16
TR1657.77336	,07	,635	,578	,56	5/8-11	.0360	17/32	3/16
TR1657.77536	,07	,635	,578	,56	5/8-11	.0361	17/32	3/16
TR1657.77337	,10	,700	,641	,68	11/16-11NS	.0370	19/32	3/16
TR1657.77537	,10	,700	,641	,68	11/16-11NS	.0371	19/32	3/16
TR1657.77338	,10	,822	,766	,75	13/16-16	.0380	23/32	3/16
TR1657.77538	,10	,822	,766	,75	13/16-16	.0381	23/32	3/16
TR1657.77339	,10	,885	,828	,94	7/8-14	.0390	25/32	3/16
TR1657.77539	,10	,885	,828	,94	7/8-14	.0391	25/32	3/16
TR1657.77340	,10	1.020	,937	1.00	1-12	.0400	27/32	5/16
TR1657.77540	,10	1.020	,937	1.00	1-12	.0401	27/32	5/16
TR1657.77341	,10	1.270	1.187	1.44	1-1/4-12	.0410	1-3/32	5/16
TR1657.77541	,10	1.270	1.187	1.44	1-1/4-12	.0411	1-3/32	5/16
TR1657.77342	,10	1.395	1.312	1.56	1-3/8-12	.0420	1-7/32	5/16
TR1657.77542	,10	1.395	1.312	1.56	1-3/8-12	.0421	1-7/32	5/16
TR1657.77343	,10	1.520	1.437	1.68	1-1/2-12	.0430	1-11/32	5/16
TR1657.77543	,10	1.520	1.437	1.68	1-1/2-12	.0431	1-11/32	5/16