

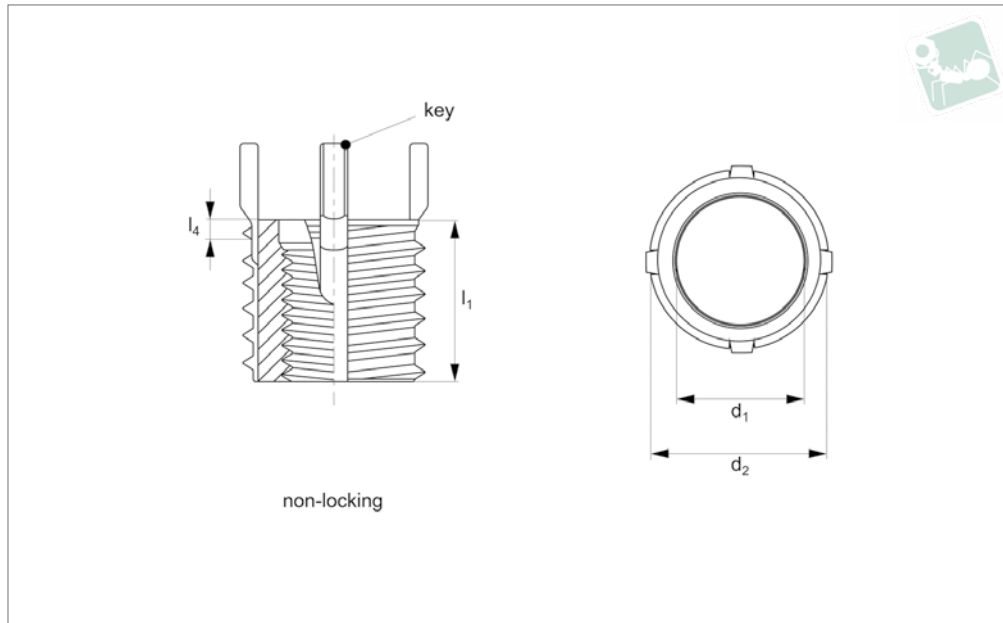

Threaded Insert MS/NAS - Thinwall - 4140 steel - non-locking - MS/NAS grade

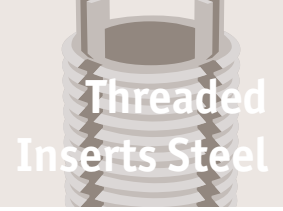

TR1662

THREADED INSERTS STEEL

Material

Inserts - 4140 alloy steel (160 KSI Min).
Keys - 302 CRES.
Cadmium plate (QQ-P-416 Type II, Cl. 2).
Dry film lubrication on self-locking inserts only.

Technical Notes

All dimensions in inches.
Internal threads: to SAE AS8879.
General tolerances -

+/- 0,010 unless specified.

Tap drill hole tolerances -
0,234 to 0,500 = +0,004/-0,001
0,500 and over = +0,005/-0,001
NL = Non-Locking type.

Tips

Order installation tool separately, as identified by „Inst. Tool ref.“ in table.

Important Notes

Four locking keys on internal threads 5/16 and over. Two locking keys on internal threads smaller than 5/16.
Installation (Inst.) drill size, counter sink, thread tap and thread depth as specified in table.
Removal (Rem.) drill size and drill depth as specified in table.
Perform to standards: MIL-I-45914A

Order No.	Type	d ₁ class 3B	Thread type d ₁	d ₂ (mod.) class 2A	Thread type d ₂	Inst. tap drill size	l ₁	l ₄ c'bore depth	Inst. c'sink hole size +0.010 - 0.000	Inst. thread depth min.	Inst. tap size class 2B	Inst. tool ref. TR1702	Removal drill depth	Removal drill size
TR1662.80321	NL	10-24	UNC	5/16-18	UNC	,272	,312	,07	,323	,37	5/16-18	.0210	5/32	7/32
TR1662.80521	NL	10-32	UNF	5/16-18	UNC	,272	,312	,07	,323	,37	5/16-18	.0211	5/32	7/32
TR1662.80322	NL	1/4-20	UNC	3/8-16	UNC	,332	,375	,07	,385	,43	3/8-16	.0220	3/16	9/32
TR1662.80522	NL	1/4-28	UNF	3/8-16	UNC	,332	,375	,07	,385	,43	3/8-16	.0221	3/16	9/32
TR1662.80323	NL	5/16-18	UNC	7/16-14	UNC	,397	,437	,07	,447	,50	7/16-14	.0230	3/16	11/32
TR1662.80523	NL	5/16-24	UNF	7/16-14	UNC	,397	,437	,07	,447	,50	7/16-14	.0231	3/16	11/32
TR1662.80324	NL	3/8-16	UNC	1/2-13	UNC	,453	,500	,07	,510	,56	1/2-13	.0240	3/16	13/32
TR1662.80524	NL	3/8-24	UNF	1/2-13	UNC	,453	,500	,07	,510	,56	1/2-13	.0241	3/16	13/32
TR1662.80325	NL	7/16-14	UNC	9/16-12	UNC	,516	,562	,07	,572	,62	9/16-12	.0250	3/16	15/32
TR1662.80525	NL	7/16-20	UNF	9/16-12	UNC	,516	,562	,07	,572	,62	9/16-12	.0251	3/16	15/32
TR1662.80326	NL	1/2-13	UNC	5/8-11	UNC	,578	,625	,07	,635	,68	5/8-11	.0260	3/16	17/32
TR1662.80526	NL	1/2-20	UNF	5/8-11	UNC	,578	,625	,07	,635	,68	5/8-11	.0261	3/16	17/32