

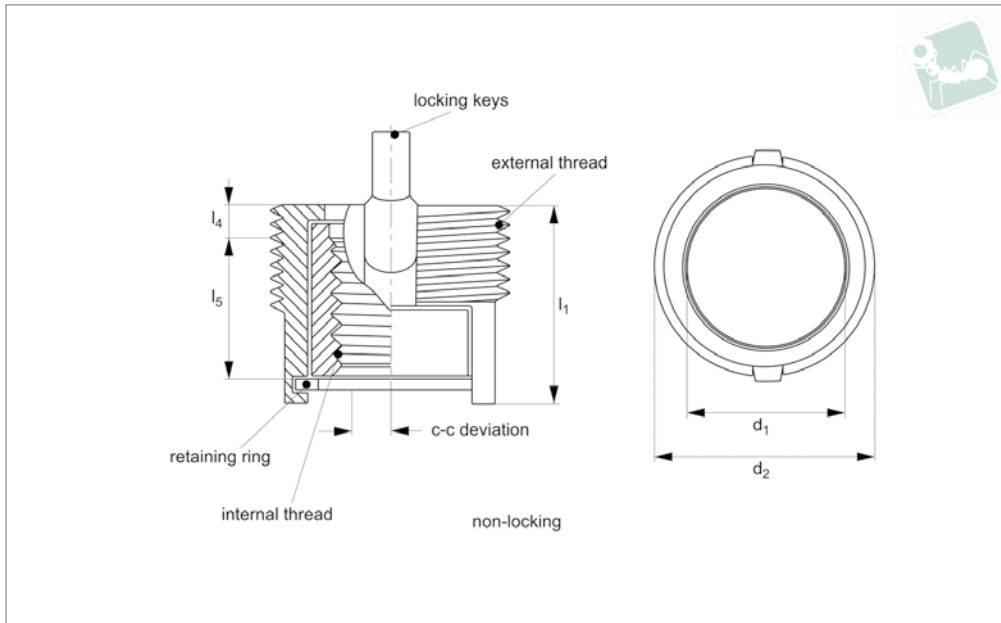

Floating Threaded Insert - Mini - Inch

303 stainless steel - non-locking

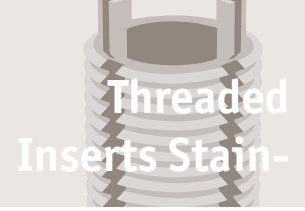

TR1680

THREADED INSERTS STAINLESS

Material

Inserts - 303 CRES.
 Keys and retaining ring - 302 CRES.
 Passivated. Dry film lubrication on self-locking inserts only.

Technical Notes

All dimensions in inches.
 Internal threads: to SAE AS8879.
 General tolerances -

+/- 0,010 unless specified.
 Tap drill hole tolerances -
 0,130 to 0,233 = +0,003/-0,001
NL = Non-thread locking type.

Tips

Order installation tool separately, as identified by „Inst. Tool ref.“ in table.

Important Notes

Four locking keys on internal threads 5/16 and over. Two locking keys on internal threads smaller than 5/16.
 Installation (Inst.) drill size, counter sink, thread tap and thread depth as specified in table.
 Removal (Rem.) drill size and drill depth as specified in table.

Order No.	Type	d ₁ tol. 3B	Thread type d ₁	l ₁ ±0.01 5	d ₂ tol. 2A	Thread type d ₂	l ₄	l ₅	c-c float min.	Inst. c'sink dia. +0.01 0 - 0.000	Inst. tap drill size	Inst. thread tap depth min.	Inst. thread tap size class 2B	Inst. tool ref. TR1720	Removal drill size	Removal drill depth
TR1680.87283	NL	2-56	UNC	,19	1/4-28	UNF	,05	,10	,015	,250	,228	,12	1/4-28	.0830	#8	3/32
TR1680.87284	NL	4-40	UNC	,32	5/16-24	UNF	,07	,21	,020	,323	,272	,31	5/16-24	.0840	7/32	1/8
TR1680.87285	NL	6-32	UNC	,36	3/8-24	UNF	,08	,22	,030	,385	,332	,38	3/8-24	.0850	9/32	1/8
TR1680.87286	NL	8-32	UNC	,36	3/8-24	UNF	,08	,22	,030	,385	,332	,38	3/8-24	.0860	9/32	1/8