

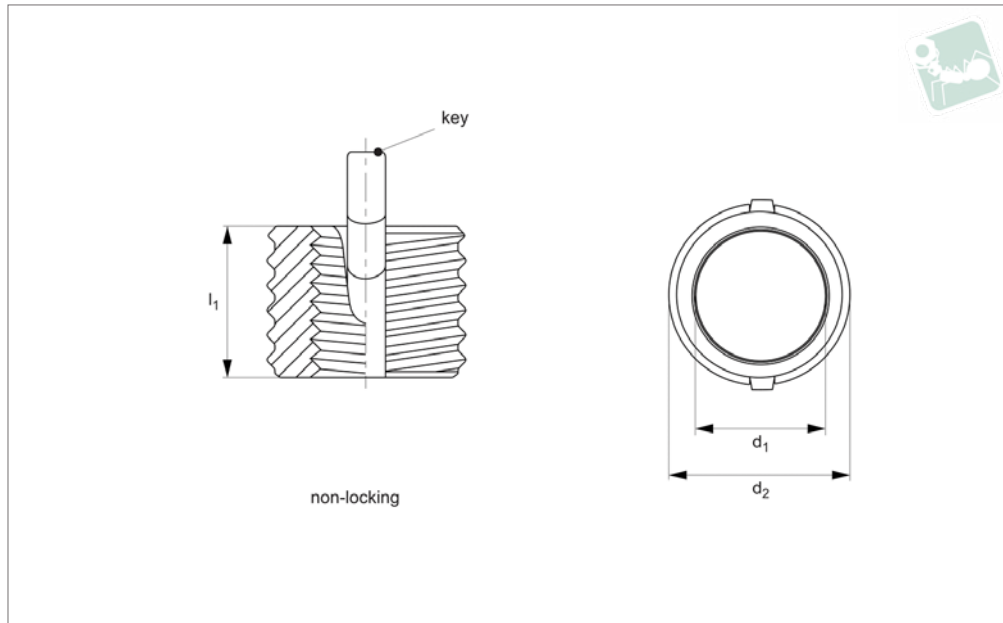

# Threaded Insert MS/NAS - Mini - 303 stainless steel - non-locking - MS/NAS grade

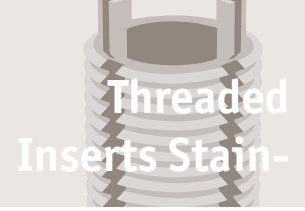

**TR1600**

THREADED INSERTS STAINLESS

### Material

Inserts - 303 CRES.  
Keys - 302 CRES.  
Passivated. Dry film lubrication on self-locking inserts only.

### General tolerances -

+/- 0,25mm, unless specified.  
Tap drill hole tolerances -  
6,9 to 10,8 = +0,100/-0,025  
12,8 and over = +0,130/-0,025  
**NL** = Non-Locking type.

### Important Notes

Four locking keys on internal threads M6 and over. Two locking keys on internal threads smaller than M6.  
Installation (Inst.) drill size, counter sink, thread tap and thread depth as specified in table.  
Removal (Rem.) drill size and drill depth as specified in table.

### Technical Notes

All dimensions in millimetres.  
Internal threads: to Fed. Std. H28/21, MJ Form

### Tips

Order installation tool separately, as identified by „Inst. Tool ref.“ in table.

Order No.	Type	d <sub>1</sub> tol. 4H 6H	Thread type d <sub>1</sub>	d <sub>2</sub> tol. 4h	Thread type d <sub>2</sub>	l <sub>1</sub>	Inst. c'sink hole size +0.25 -0.00	Inst. tap drill size +0.080 - 0.025	Inst. tap to depth min.	Inst. thread tap tol. 6H	Inst. tool ref. TR1710	Removal drill size	Removal drill depth
<b>TR1600.76382</b>	NL	M 2x0, 4	Coarse	M 4x0, 7	Coarse	3.00	4.1	3.4	4.0	M 4x0,7	.0820	2.8	2.00
<b>TR1600.76383</b>	NL	M2,5 x0,4 5	Coarse	M4,5 x0,7 5	Coarse	3.81	4.6	3.9	5.0	M4,5x0 ,75	.0830	3.0	2.00
<b>TR1600.76384</b>	NL	M 3x0, 5	Coarse	M 5x0, 8	Coarse	4.25	5.1	4.4	5.5	M 5x0,8	.0840	3.5	2.25
<b>TR1600.76386</b>	NL	M 4x0, 7	Coarse	M 6x0, 75	Fine	5.25	6.1	5.5	6.5	M 6x0,75	.0860	4.6	2.50



**TR1601**

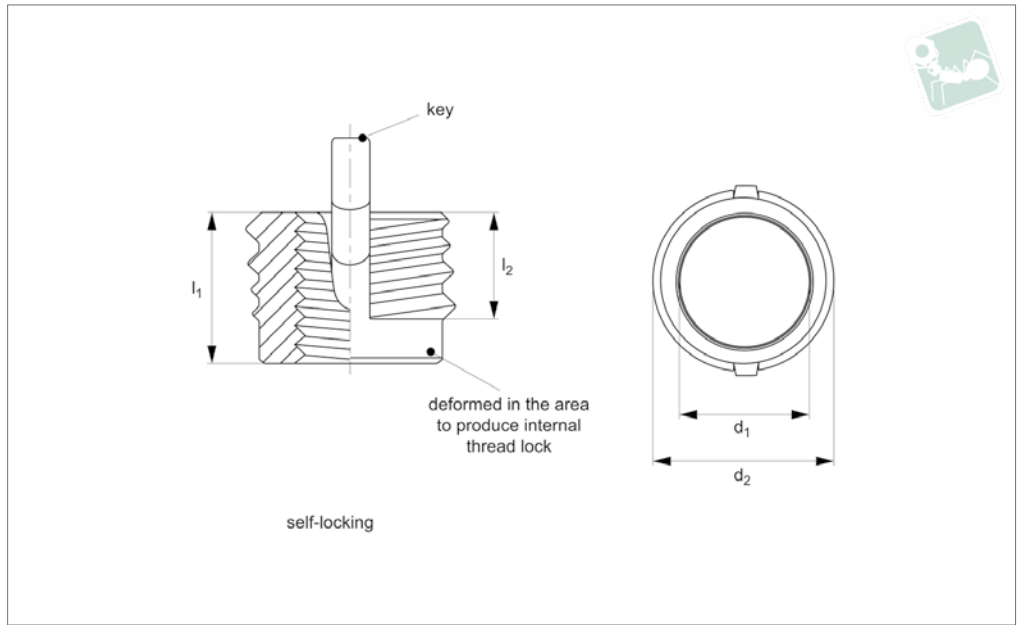

**Material**

Inserts - 303 CRES.  
Keys - 302 CRES.  
Passivated. Dry film lubrication on self-locking inserts only.

**Technical Notes**

All dimensions in millimetres.  
Internal threads: to Fed. Std. H28/21, MJ Form  
General tolerances -

+/- 0,25mm, unless specified.

Tap drill hole tolerances -  
6,9 to 10,8 = +0,100/-0,025  
12,8 and over = +0,130/-0,025

**SL** = Self-Locking type, deliberate deformity in thread produces self-affect once installed (see technical diagram).

**Tips**

Order installation tool separately, as identified by „Inst. Tool ref.“ in table.

**Important Notes**

Four locking keys on internal threads M6 and over. Two locking keys on internal threads smaller than M6.

Installation (Inst.) drill size, counter sink, thread tap and thread depth as specified in table.

Removal (Rem.) drill size and drill depth as specified in table.

Order No.	Type	d <sub>1</sub> tol. 4H 6H	Thread type d <sub>1</sub>	d <sub>2</sub> tol. 4h	Thread type d <sub>2</sub>	l <sub>1</sub>	l <sub>2</sub>	Inst. c'sink hole size +0.25 -0.00	Inst. tap drill size +0.080  -0.025	Inst. tap to depth min.	Inst. thread tap tol. 6H	Inst. tool ref. TR1710	Removal drill size	Removal drill depth
<b>TR1601.77382</b>	SL	M 2x0, 4	Coarse	M 4x0, 7	Coarse	3.00	2.20	4.1	3.4	4.0	M 4x0,7	.0820	2.8	2.00
<b>TR1601.77383</b>	SL	M2,5 x0,4 5	Coarse	M4,5 x0,7 5	Coarse	3.81	2.70	4.6	3.9	5.0	M4,5x 0,75	.0830	3.0	2.00
<b>TR1601.77384</b>	SL	M 3x0, 5	Coarse	M 5x0, 8	Coarse	4.25	3.10	5.1	4.4	5.5	M 5x0,8	.0840	3.5	2.25
<b>TR1601.77386</b>	SL	M 4x0, 7	Coarse	M 6x0, 75	Fine	5.25	4.11	6.1	5.5	6.5	M 6x0,75	.0860	4.6	2.50



# Threaded Insert MS/NAS - Mini - Inch

303 stainless steel - non-locking - MS/NAS grade

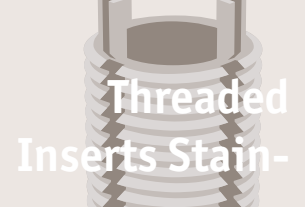

Threaded Inserts Stain-

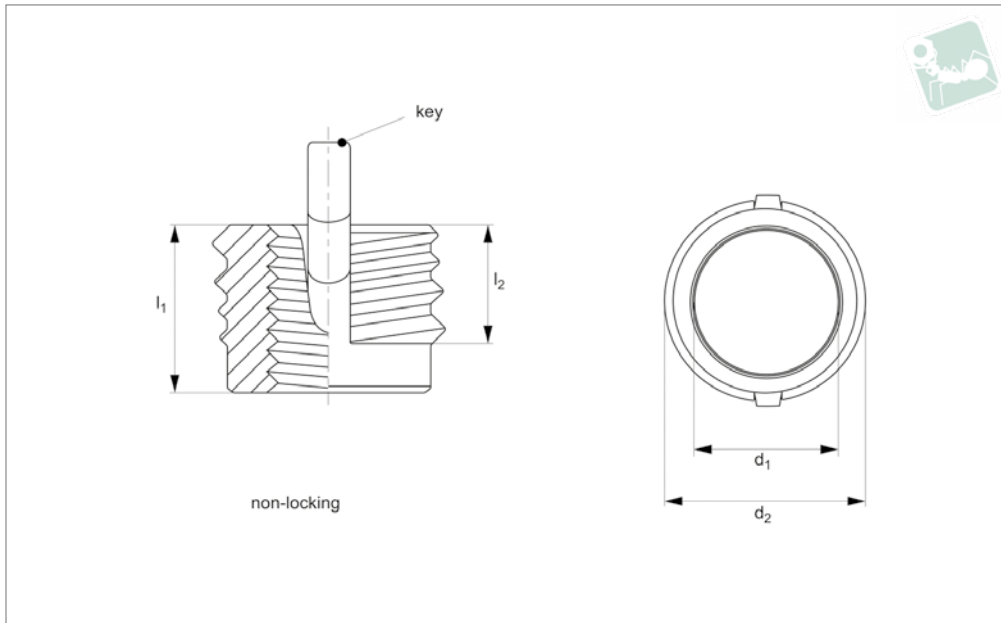

**TR1650**

THREADED INSERTS STAINLESS

### Material

Inserts - 303 CRES.  
Keys - 302 CRES.  
Passivated. Dry film lubrication on self-locking inserts only.

### Technical Notes

All dimensions in inches.  
Internal threads: to SAE AS8879.  
General tolerances -  
+/- 0,010 unless specified.

Tap drill hole tolerances -  
0,234 to 0,500 = +0,004/-0,001  
0,500 and over = +0,005/-0,001  
**NL** = Non-Locking type.

### Tips

Order installation tool separately, as identified by „Inst. Tool ref.“ in table.

### Important Notes

Four locking keys on internal threads 5/16

and over. Two locking keys on internal threads smaller than 5/16.  
Installation (Inst.) drill size, counter sink, thread tap and thread depth as specified in table.  
Removal (Rem.) drill size and drill depth as specified in table.  
Perform to standards: MIL-I-45914A (MS51830)  
\* Modified minor dia.

Order No.	Type	d <sub>1</sub> tol. 3B type	Thread d <sub>1</sub> type	d <sub>2</sub> tol. 2A type	Thread d <sub>2</sub> type	l <sub>1</sub>	l <sub>2</sub>	C'sink hole size	Inst. tap drill size +0.00 3 - 0 - 0.000	Inst. thread tap depth min.	Inst. thread tap size tol. 6B	Inst. tool ref. TR1700	Removal drill size	Removal drill depth
<b>TR1650.76283</b>	NL	2-56	UNC	8-32	UNC	,120	,090	,166	,134	,140	8-32	.0830	#33	1/16
<b>TR1650.76284</b>	NL	4-40	UNC	10-32	UNF	,170	,125	,194	,161	,160	10-32	.0840	#29	3/32
<b>TR1650.76285</b>	NL	6-32	UNC	12-28	UNF	,170	,125	,220	,187	,160	12-28	.0850	#21	3/32
<b>TR1650.76286</b>	NL	8-32	UNC	1/4-28*	UNF	,220	,175	,255	,228	,210	1/4-28	.0860	#8	1/8



TR1651

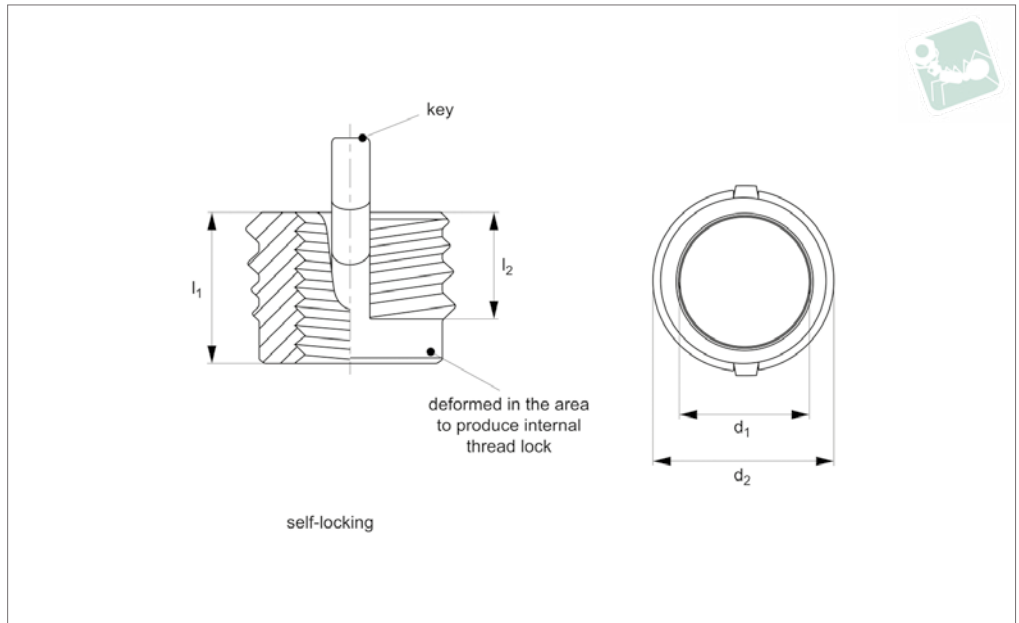

**Material**

Inserts - 303 CRES.  
Keys - 302 CRES.  
Passivated. Dry film lubrication on self-locking inserts only.

**Technical Notes**

All dimensions in inches.  
Internal threads: to SAE AS8879.  
General tolerances -  
+/- 0,010 unless specified.  
Tap drill hole tolerances -

0,234 to 0,500 = +0,004/-0,001  
0,500 and over = +0,005/-0,001  
**SL** = Self-Locking type, deliberate deformity in thread produces self-affect once installed (see technical diagram).

**Tips**

Order installation tool separately, as identified by „Inst. Tool ref.“ in table.

**Important Notes**

Four locking keys on internal threads 5/16

and over. Two locking keys on internal threads smaller than 5/16.  
Installation (Inst.) drill size, counter sink, thread tap and thread depth as specified in table.  
Removal (Rem.) drill size and drill depth as specified in table.  
Perform to standards: MIL-I-45914A (MS51830)  
\* Modified minor dia.

Order No.	Type	d <sub>1</sub> tol. 3B type	Thread d <sub>1</sub>	d <sub>2</sub> tol. 2A type	Thread d <sub>2</sub>	l <sub>1</sub>	l <sub>2</sub>	C'sink hole size	Inst. tap drill +0.00 3 - 0 - 0.001	Inst. thread tap depth min.	Inst. thread tap size tol. 6B	Inst. tool ref. TR1700	Removal drill size	Removal drill depth
TR1651.77283	SL	2-56	UNC	8-32	UNC	,120	,090	,166	,134	,140	8-32	.0830	#33	1/16
TR1651.77284	SL	4-40	UNC	10-32	UNF	,170	,125	,194	,161	,160	10-32	.0840	#29	3/32
TR1651.77285	SL	6-32	UNC	12-28	UNF	,170	,125	,220	,187	,160	12-28	.0850	#21	3/32
TR1651.77286	SL	8-32	UNC	1/4-28*	UNF	,220	,175	,255	,228	,210	1/4-28	.0860	#8	1/8



# Blind Threaded Insert - Mini - Inch

303 stainless steel - non-locking

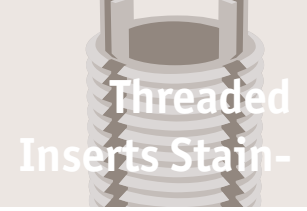

Threaded Inserts Stain-

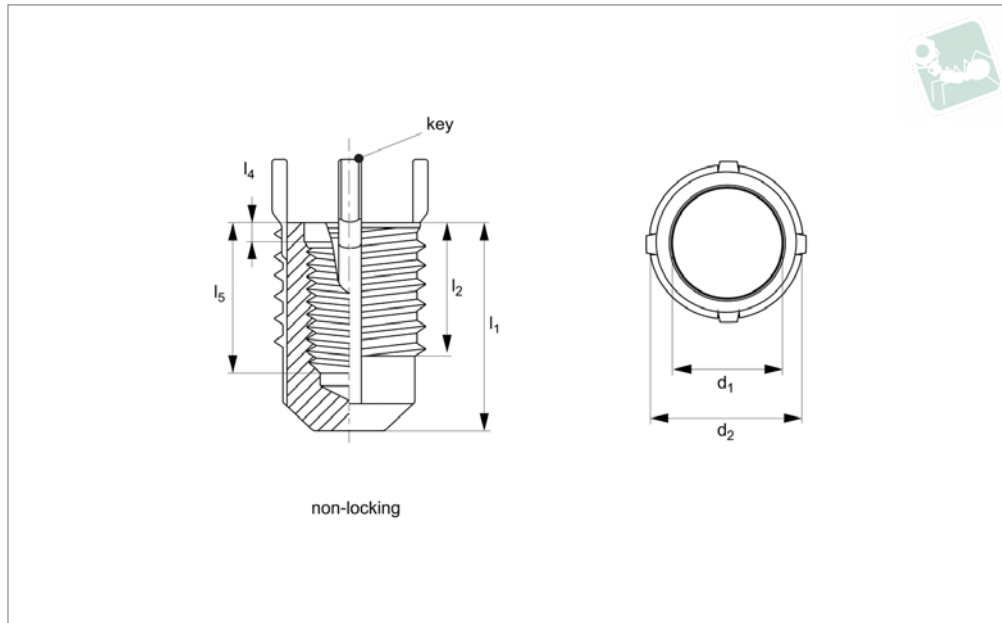

**TR1670**

THREADED INSERTS STAINLESS

### Material

Inserts - A303 CRES.  
Keys - 302 CRES.  
Passivated. Dry film lubrication on self-locking inserts only.

### Technical Notes

All dimensions in inches.  
Internal threads: to SAE AS8879.  
General tolerances -  
+/- 0,010 unless specified.

Tap drill hole tolerances -  
0,234 to 0,500 = +0,004/-0,001  
0,500 and over = +0,005/-0,001  
**NL** = Non-Locking type.

### Tips

Order installation tool separately, as identified by „Inst. Tool ref.“ in table.

### Important Notes

Four locking keys on internal threads 5/16

and over. Two locking keys on internal threads smaller than 5/16.  
Installation (Inst.) drill size, counter sink, thread tap and thread depth as specified in table.  
Removal (Rem.) drill size and drill depth as specified in table.  
Perform to standards: MIL-I-45914A

Order No.	Type	d <sub>1</sub> tol. 3B	Thre ad type d <sub>1</sub>	d <sub>2</sub> tol. 2A	Thre ad type d <sub>2</sub>	l <sub>1</sub>	l <sub>2</sub>	l <sub>4</sub> c'bore depth	l <sub>5</sub>	Inst. c'sink hole size +0.010  -0.000	Inst. tap drill size	Inst. thread tap depth min.	Inst. thread tap size class 2B	Inst. tool ref. TR1700	Remo val drill size	Removal drill depth
TR1670.83290	NL	2-56	UNC	8-32	UNC	,24	,18	C'Sin k	,13	,166	,134	,24	8-32	.0830	#33	1/16
TR1670.83291	NL	4-40	UNC	10-32	UNF	,31	,22	C'Sin k	,17	,194	.161	,28	10-32	.0840	#29	3/32
TR1670.83292	NL	6-32	UNC	12-28	UNF	,39	,22	C'Sin k	,21	,220	,187	,28	12-28	.0850	#21	3/32
TR1670.83294	NL	8-32	UNC	1/4-28	UNF	,43	,24	C'Sin k	,25	,255	,228	,30	1/4-28	.0860	#8	3/32



**TR1671**

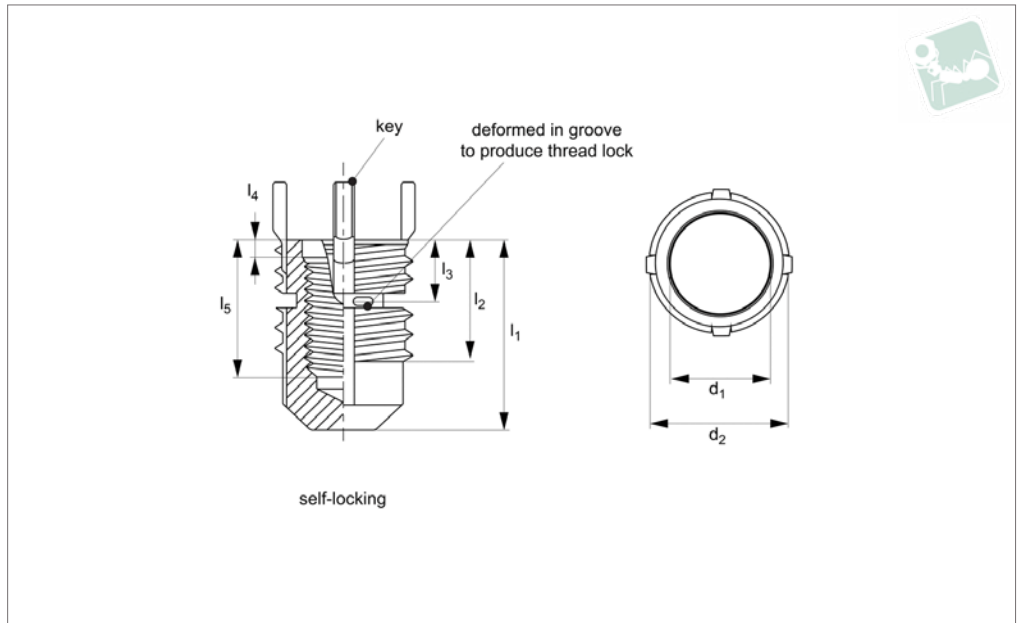

**Material**

Inserts - A303 CRES.  
Keys - 302 CRES.  
Passivated. Dry film lubrication on self-locking inserts only.

**Technical Notes**

All dimensions in inches.  
Internal threads: to SAE AS8879.  
General tolerances -  
+/- 0,010 unless specified.

**Tap drill hole tolerances -**

0,234 to 0,500 = +0,004/-0,001  
0,500 and over = +0,005/-0,001  
**SL** = Self-Locking type, deliberate deformity in thread produces self-affect once installed (see technical diagram).

**Tips**

Order installation tool separately, as identified by „Inst. Tool ref.“ in table.

**Important Notes**

Four locking keys on internal threads 5/16 and over. Two locking keys on internal threads smaller than 5/16.  
Installation (Inst.) drill size, counter sink, thread tap and thread depth as specified in table.  
Removal (Rem.) drill size and drill depth as specified in table.  
Perform to standards: MIL-I-45914A

Order No.	Type	d <sub>1</sub> tol. 3B	Thre ad type d <sub>1</sub>	d <sub>2</sub> tol. 2A	Thre ad type d <sub>2</sub>	l <sub>1</sub>	l <sub>2</sub>	l <sub>3</sub> ±0.0 30	l <sub>4</sub> c'bore depth	l <sub>5</sub>	Inst. c'sink hole size +0.010  -0.000	Inst. tap drill size	Inst. thread tap depth min.	Inst. thread tap size class 2B	Inst. tool ref. TR1700	Rem oval drill size	Removal drill depth size
<b>TR1671.84290</b>	SL	2-56	UNC	,166	UNC	,24	,18	,10	C'Sin k	,13	,166	,134	,24	8-32	.0830	#33	1/16
<b>TR1671.84291</b>	SL	4-40	UNC	,194	UNF	,31	,22	,12	C'Sin k	,17	,194	,161	,28	10-32	.0840	#29	3/32
<b>TR1671.84292</b>	SL	6-32	UNC	,220	UNF	,39	,22	,12	C'Sin k	,21	,220	,187	,28	12-28	.0850	#21	3/32
<b>TR1671.84294</b>	SL	8-32	UNC	,255	UNF	,43	,24	,13	C'Sin k	,25	,255	,228	,30	1/4-28	.0860	#8	3/32



# Threaded Insert - Metric

thinwall - stainless steel

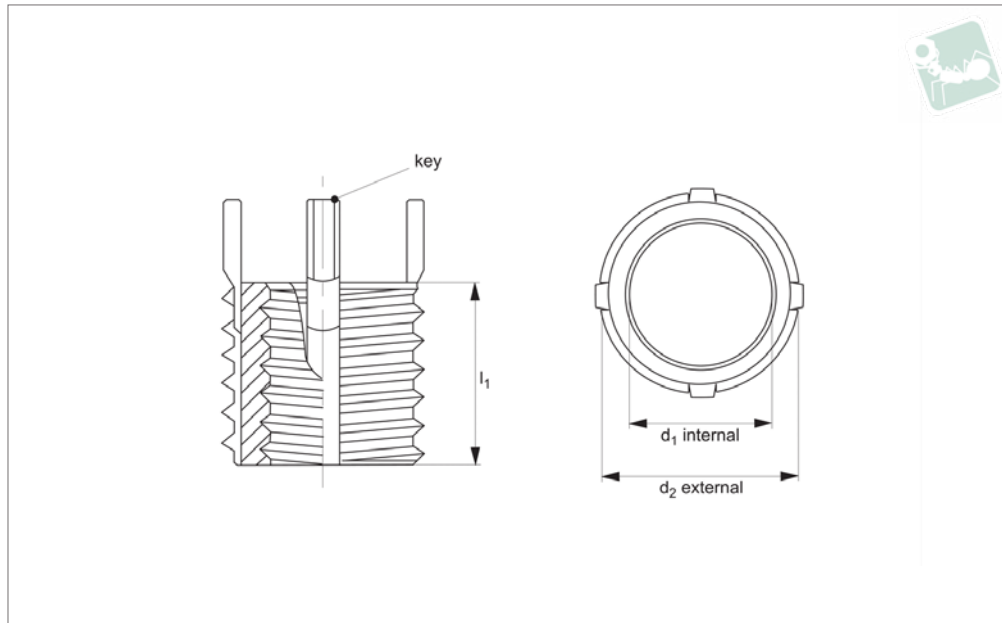
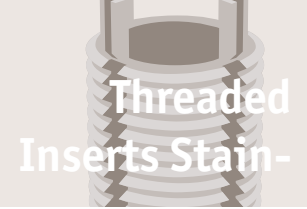

**TR1510**

THREADED INSERTS STAINLESS

### Material

Inserts: stainless steel (AISI 303) or equivalent. Passivated.

Keys: stainless steel (302 CRES) or equivalent. Passivated.

### Technical Notes

#### General tolerances:

±0,25, unless specified.

### Tap drill hole tolerances:

6,9 to 10,8 = +0,10/-0,025.

12,8 and over = +0,13/-0,025.

### Tips

Order installation tool separately, as identified by „Inst. tool ref.“ in table.

### Important Notes

Four locking keys on internal threads M 8 and over. Two locking keys on internal threads smaller than M 8.

Installation (Inst.) drill size, countersink, thread tap and thread depth as specified in table.

Removal drill size and drill depth as speci-

Order No.	Int. d <sub>1</sub> tol. 6H	Int. thread type d <sub>1</sub>	Ext. d <sub>2</sub> tol. 6g	Ext. thread type d <sub>2</sub>	l <sub>1</sub>	Inst. tap drill size	Inst. tool ref. 22060	Inst. c'sink dia. ±0,25   ± 0,000	Inst. thread tap tol. 6H	Inst. thread depth min.	Removal drill size	Removal drill depth
TR1510.66351	M 5x0,80	Coarse	M 8x1,25	Coarse	8	6,9	.W0510	8,3	M 8x1,25	9,5	5,5	4,0
TR1510.66352	M 6x1,00	Coarse	M10x1,25	Fine	10	8,8	.W0520	10,3	M10x1,25	11,5	7,5	4,8
TR1510.66353	M 8x1,25	Coarse	M12x1,25	Fine	12	10,8	.W0530	12,3	M12x1,25	13,5	9,5	4,8
TR1510.66553	M 8x1,00	Fine	M12x1,25	Fine	12	10,8	.W0530	12,3	M12x1,25	13,5	9,5	4,8
TR1510.66355	M10x1,50	Coarse	M14x1,50	Fine	14	12,8	.W0550	14,3	M14x1,50	15,5	11,5	4,8
TR1510.66555	M10x1,25	Fine	M14x1,50	Fine	14	12,8	.W0550	14,3	M14x1,50	15,5	11,5	4,8
TR1510.66356	M12x1,75	Coarse	M16x1,50	Fine	16	14,2	.W0560	14,3	M16x1,50	17,5	13,5	4,8
TR1510.66556	M12x1,25	Fine	M16x1,50	Fine	16	14,8	.W0560	16,3	M16x1,50	17,5	13,5	4,8



TR1560

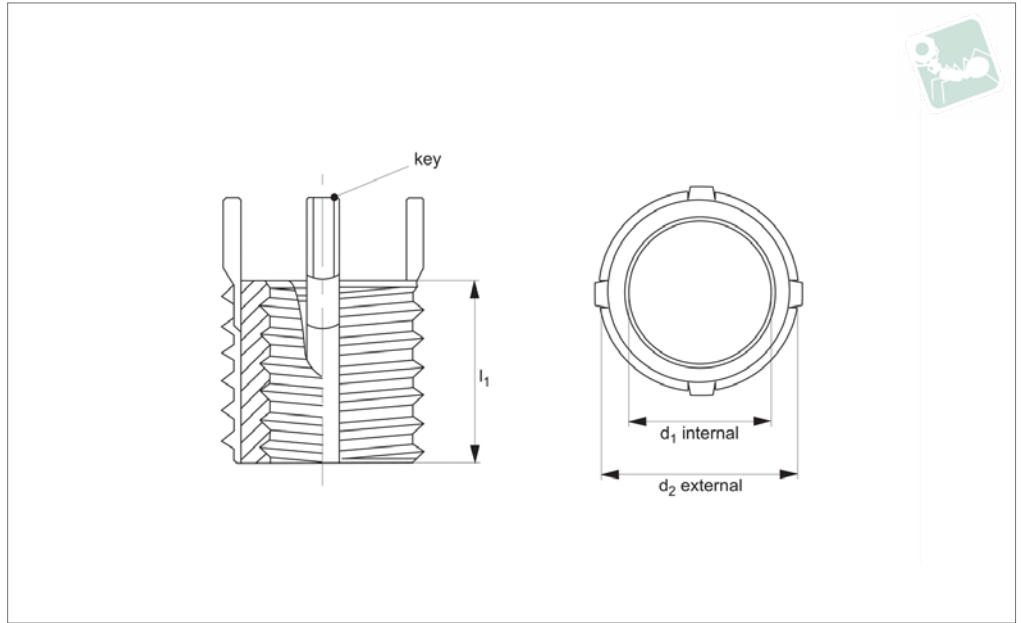

**Material**

Inserts: stainless steel (AISI 303) or equivalent. Passivated.

Keys: stainless steel (302 CRES) or equivalent. Passivated.

**Technical Notes**

All dimensions in inches.

**General tolerances:**

± 0,010" unless specified.

**Tap drill hole tolerances:**

0,234 to 0,500 = +0,004/-0,001"

0,500 and over = +0,005/-0,001"

**Tips**

Order installation tool separately, as identified by „Inst. tool ref.“ in table.

**Important Notes**

Four locking keys on internal threads 5/

16" and over. Two locking keys on internal threads smaller than 5/16".

Installation (Inst.) drill size, countersink, thread tap and thread depth as specified in table.

Removal drill size and drill depth as specified in table.

**All dimensions in inches.**

Order No.	Int. d <sub>1</sub> tol. 2B	Int. thread type d <sub>1</sub>	Ext. d <sub>2</sub> tol. 2A	Ext. thread type d <sub>2</sub>	l <sub>1</sub>	Inst. tap drill size	Inst. tool ref. 22054	Inst. c'sink dia. +0.010 -0.000	Inst. thread tap tol. 2B	Inst. thread depth min.	Removal drill size	Removal drill depth
TR1560.66321	10-24	UNC	5/16"-18	UNC	0,31	17/64"	.W0210	0,32	5/16"-18	0,37	7/32"	1/8"
TR1560.66521	10-32	UNF	5/16"-18	UNC	0,31	17/64"	.W0210	0,32	5/16"-18	0,37	7/32"	1/8"
TR1560.66322	1/4"-20	UNC	3/8"-16	UNC	0,37	21/64"	.W0220	0,38	3/8"-16	0,43	9/32"	3/16"
TR1560.66522	1/4"-28	UNF	3/8"-16	UNC	0,37	21/64"	.W0220	0,38	3/8"-16	0,43	9/32"	3/16"
TR1560.66323	5/16"-18	UNC	7/16"-14	UNC	0,43	25/64"	.W0230	0,44	7/16"-14	0,50	11/32"	3/16"
TR1560.66523	5/16"-24	UNF	7/16"-14	UNC	0,43	25/64"	.W0230	0,44	7/16"-14	0,50	11/32"	3/16"
TR1560.66324	3/8"-16	UNC	1/2"-13	UNC	0,50	29/64"	.W0240	0,51	1/2"-13	0,56	13/32"	3/16"
TR1560.66524	3/8"-16	UNF	1/2"-13	UNC	0,50	29/64"	.W0240	0,51	1/2"-13	0,56	13/32"	3/16"
TR1560.66325	7/16"-14	UNC	9/16"-12	UNC	0,56	33/64"	.W0250	0,57	9/16"-12	0,62	15/32"	3/16"
TR1560.66525	7/16"-20	UNF	9/16"-12	UNC	0,56	33/64"	.W0250	0,57	9/16"-12	0,62	15/32"	3/16"
TR1560.66326	1/2"-13	UNC	5/8"-11	UNC	0,62	37/64"	.W0260	0,63	5/8"-11	0,68	17/32"	3/16"
TR1560.66526	1/2"-20	UNF	5/8"-11	UNC	0,62	37/64"	.W0260	0,63	5/8"-11	0,68	17/32"	3/16"





# Threaded Insert MS/NAS - Thinwall - 303 stainless steel - non-locking - MS/NAS grade

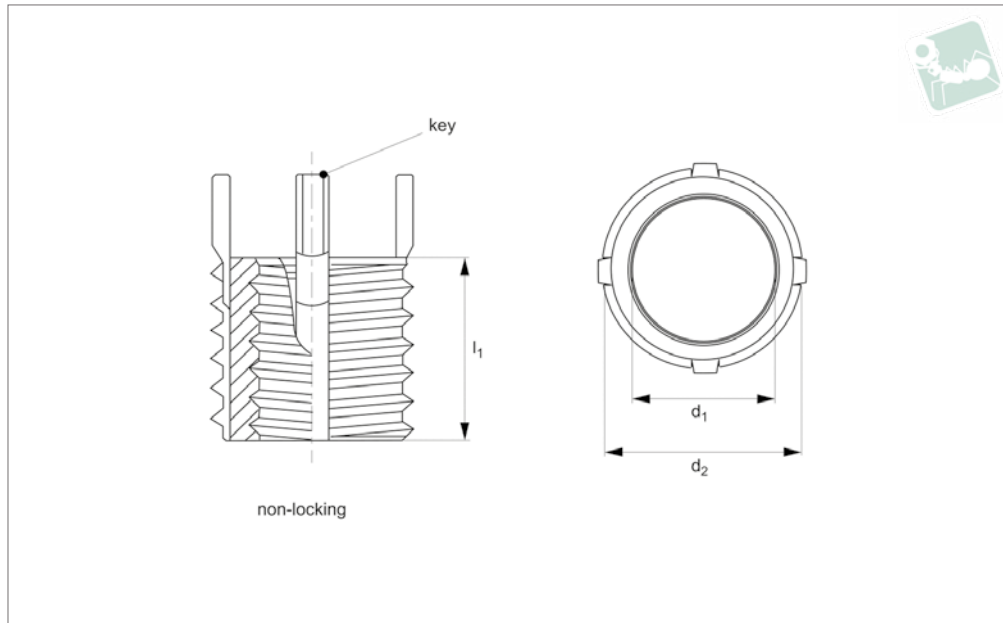
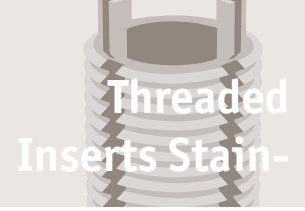

**TR1602**

THREADED INSERTS STAINLESS

### Material

Inserts - 303 CRES.  
Keys - 302 CRES.  
Passivated. Dry film lubrication on self-locking inserts only.

### Technical Notes

All dimensions in millimetres.  
Internal threads: to Fed. Std. H28/21, MJ Form

### General tolerances -

+/- 0,25mm, unless specified.  
Tap drill hole tolerances -  
6,9 to 10,8 = +0,100/-0,025  
12,8 and over = +0,130/-0,025  
**NL** = Non-Locking type.

### Tips

Order installation tool separately, as identified by „Inst. Tool ref.“ in table.

### Important Notes

Four locking keys on internal threads M 6 and over. Two locking keys on internal threads smaller than M 6.  
Installation (Inst.) drill size, counter sink, thread tap and thread depth as specified in table.  
Removal (Rem.) drill size and drill depth as specified in table.

Order No.	Type	d <sub>1</sub> tol. 4H type 5H	Thread d <sub>1</sub>	d <sub>2</sub> tol. 4h type	Thread d <sub>2</sub>	Inst. tap drill size	l <sub>1</sub>	l <sub>4</sub> c'bore depth	C'sink hole size +0.25  -0.00	Inst. thread tap tol. 6H	Inst. thread tap depth min.	Inst. tool ref. TR1712	Removal drill depth	Removal drill size
TR1602.76351	NL	M 5x0,8	Coars e	M 8x1,25	Coars e	6.90	8.0	1.27	8.25	M 8x1,25	9.5	.0510	4.00	5.50
TR1602.76551	NL	M 5x0,5	Fine	M 8x1,25	Coars e	6.90	8.0	1.27	8.25	M 8x1,25	9.5	.0510	4.00	5.50
TR1602.76352	NL	M 6x1,0	Coars e	M10 x1,25	Fine	8.80	10.0	1.78	10.25	M10x1,25	11.5	.0520	4.75	7.50
TR1602.76552	NL	M 6x0,75	Fine	M10 x1,25	Fine	8.80	10.0	1.78	10.25	M10x1,25	11.5	.0520	4.75	7.50
TR1602.76353	NL	M 8x1,25	Coars e	M12 x1,25	Fine	10.80	12.0	1.78	12.25	M12.1,25	13.5	.0530	4.75	9.50
TR1602.76553	NL	M 8x1,0	Fine	M12 x1,25	Fine	10.80	12.0	1.78	12.25	M12.1,25	13.5	.0530	4.75	9.50
TR1602.76355	NL	M10 x1,5	Coars e	M14 x1,5	Fine	12.80	14.0	2.29	14.25	M14x1,5	15.5	.0550	4.75	11.50
TR1602.76555	NL	M10 x1,25	Fine	M14 x1,5	Fine	12.80	14.0	2.29	14.25	M14x1,5	15.5	.0550	4.75	11.50



Order No.	Type	d <sub>1</sub> tol. 4H	Thread type d <sub>1</sub>	d <sub>2</sub> tol. 4h	Thread type d <sub>2</sub>	Inst. tap drill size	l <sub>1</sub>	l <sub>4</sub> c'bore depth	C'sink hole size +0.25   -0.00	Inst. thread tap tol. 6H	Inst. thread tap depth min.	Inst. tool ref. TR1712	Removal drill depth	Removal drill size
<b>TR1602.76356</b>	NL	M12 x1,75	Coarse	M16 x1,5	Fine	14.75	16.0	2.29	16.25	M16x1,5	17.5	.0560	4.75	13.50
<b>TR1602.76556</b>	NL	M12 x1,25	Fine	M16 x1,5	Fine	14.75	16.0	2.29	16.25	M16x1,5	17.5	.0560	4.75	13.50



# Threaded Insert MS/NAS - Thinwall - 303 stainless steel - self-locking - MS/NAS grade

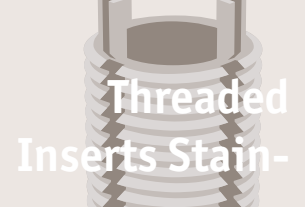

Threaded  
Inserts Stain-

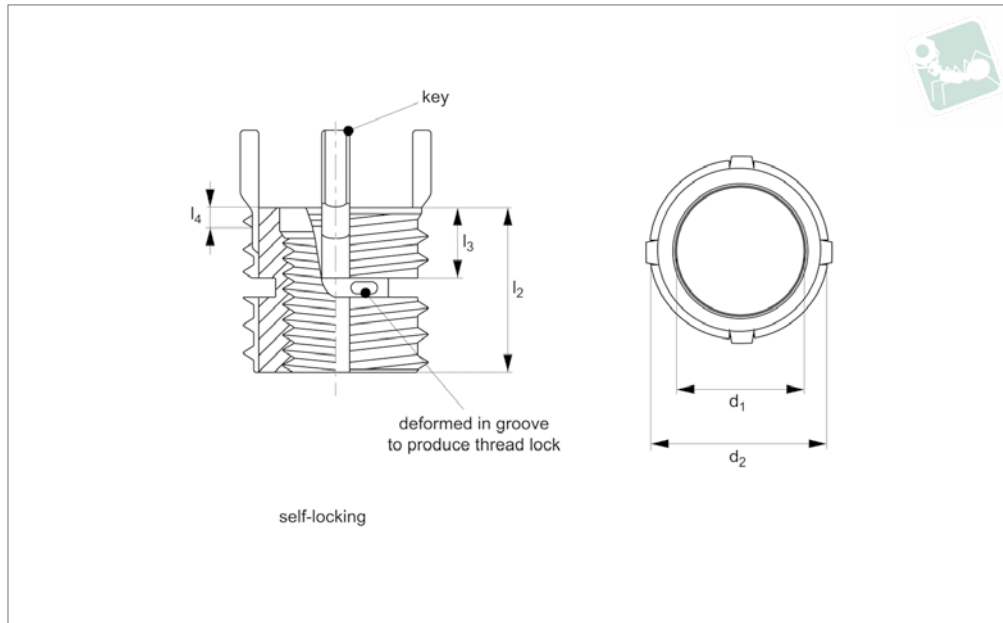

**TR1603**

THREADED INSERTS STAINLESS

### Material

Inserts - 303 CRES.  
Keys - 302 CRES.  
Passivated. Dry film lubrication on self-locking inserts only.

### Technical Notes

All dimensions in millimetres.  
Internal threads: to Fed. Std. H28/21, MJ Form  
General tolerances -

+/- 0,25mm, unless specified.

Tap drill hole tolerances -  
6,9 to 10,8 = +0,100/-0,025  
12,8 and over = +0,130/-0,025

**SL** = Self-Locking type, deliberate deformity in thread produces self-affect once installed (see technical diagram).

### Tips

Order installation tool separately, as identified by „Inst. Tool ref.“ in table.

### Important Notes

Four locking keys on internal threads M 6 and over. Two locking keys on internal threads smaller than M 6.  
Installation (Inst.) drill size, counter sink, thread tap and thread depth as specified in table.  
Removal (Rem.) drill size and drill depth as specified in table.

Order No.	Type	d <sub>1</sub> tol. 4H 5H	Thread d <sub>1</sub>	Coars e	d <sub>2</sub> 4htype	Thread d <sub>2</sub>	Coars e	Inst. tap drill size	l <sub>1</sub>	l <sub>3</sub> ±0.76	l <sub>4</sub> e ±0.76	c'bor h	C'sink hole size +0.25  -0.00	Inst. thread tap tol. 6H	Inst. thread tap depth min.	Inst. tool ref. TR1712	Removal drill depth	Removal drill size
TR1603.77351	SL	M 5x0, 8	Coars e	M 8x1, 25	Coars e	6.90	8.0	3.73	1.27	8.25	M 8x1,2 5	9.5	.0510	4.00	5.50			
TR1603.77551	SL	M 5x0, 5	Fine	M 8x1, 25	Coars e	6.90	8.0	3.73	1.27	8.25	M 8x1,2 5	9.5	.0510	4.00	5.50			
TR1603.77352	SL	M 6x1, 0	Coars e	M10 x1,2 5	Fine	8.80	10.0	6.02	1.78	10.25	M10x 1,25	11.5	.0520	4.75	7.50			
TR1603.77552	SL	M 6x0, 75	Fine	M10 x1,2 5	Fine	8.80	10.0	6.02	1.78	10.25	M10x 1,25	11.5	.0520	4.75	7.50			
TR1603.77353	SL	M 8x1, 25	Coars e	M12 x1,2 5	Fine	10.80	12.0	6.28	1.78	12.25	M12x 1,25	13.5	.0530	4.75	9.50			
TR1603.77553	SL	M 8x1, 0	Fine	M12 x1,2 5	Fine	10.80	12.0	6.28	1.78	12.25	M12x 1,25	13.5	.0530	4.75	9.50			
TR1603.77355	SL	M10 x1,5	Coars e	M14 x1,5	Fine	12.80	14.0	6.46	2.29	14.25	M14x 1,5	15.5	.0550	4.75	11.50			
TR1603.77555	SL	M10 x1,2 5	Fine	M14 x1,5	Fine	12.80	14.0	6.46	2.29	14.25	M14x 1,5	15.5	.0550	4.75	11.50			



Order No.	Type	d <sub>1</sub> tol. 4H 5H	Thread type d <sub>1</sub>	d <sub>2</sub> tol. 4h	Thread type d <sub>2</sub>	Inst. tap drill size	l <sub>1</sub>	l <sub>3</sub> ±0.76	l <sub>4</sub> e	c'bor dept h	C'sink hole size +0.25  -0.00	Inst. thread tap tol. 6H	Inst. thread tap depth min.	Inst. tool ref. TR1712	Removal drill depth	Removal drill size
<b>TR1603.77356</b>	SL	M12 x1,7 5	Coars e	M16 x1,5	Fine	14.75	16.0	6.46	2.29	16.25	M16x 1,5	17.5	.0560		4.75	13.50
<b>TR1603.77556</b>	SL	M12 x1,2 5	Fine	M16 x1,5	Fine	14.75	16.0	6.46	2.29	16.25	M16x 1,5	17.5	.0560		4.75	13.50



# Threaded Insert MS/NAS - Thinwall - 303 stainless steel - non-locking - MS/NAS grade

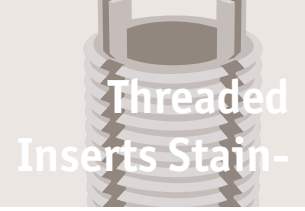

Threaded  
Inserts Stain-

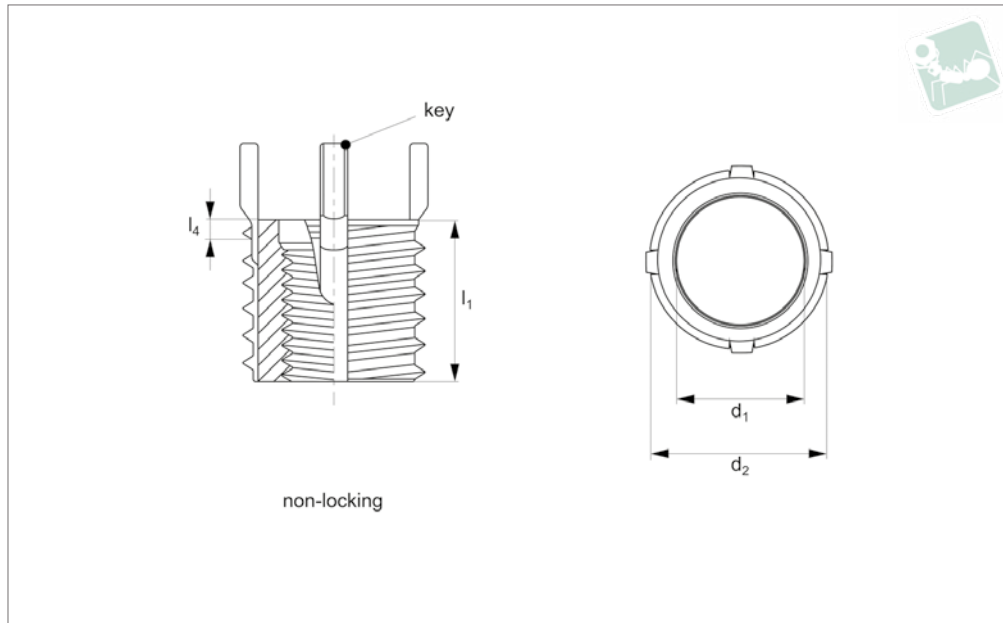

**TR1652**

THREADED INSERTS STAINLESS

### Material

Inserts - 303 CRES.  
Keys - 302 CRES.  
Passivated. Dry film lubrication on self-locking inserts only.

### Technical Notes

All dimensions in inches.  
Internal threads: to SAE AS8879.  
General tolerances -  
+/- 0,010 unless specified.

Tap drill hole tolerances -  
0,234 to 0,500 = +0,004/-0,001  
0,500 and over = +0,005/-0,001  
**NL** = Non-Locking type.

### Tips

Order installation tool separately, as identified by „Inst. Tool ref.“ in table.

### Important Notes

Four locking keys on internal threads 5/16

and over. Two locking keys on internal threads smaller than 5/16.  
Installation (Inst.) drill size, counter sink, thread tap and thread depth as specified in table.  
Removal (Rem.) drill size and drill depth as specified in table.  
Perform to standards: MIL-I-45914A (MS51830 & NAS1394)

Order No.	Type	d <sub>1</sub> tol. 3B	Thread type d <sub>1</sub>	d <sub>2</sub> (mod.) class 2A	Thread type d <sub>2</sub>	Inst. tap drill size	l <sub>1</sub>	l <sub>4</sub> c'bor e dept h	C'sink hole size +0.01 0 - 0.000	Inst. thread tap depth min.	Inst. thread tap size tol. 2B	Inst. tool ref. TR1702	Removal drill depth	Removal drill size
TR1652.76321	NL	10-24	UNC	5/16-18	UNC	,397	,437	,07	,447	,50	7/16-14	.0210	3/16	11/32
TR1652.76521	NL	10-32	UNF	5/16-18	UNC	,397	,437	,07	,447	,50	7/16-14	.0211	3/16	11/32
TR1652.76322	NL	1/4-20	UNC	3/8-16	UNC	,272	,312	,07	,323	,37	5/16-18	.0220	5/32	7/32
TR1652.76522	NL	1/4-28	UNF	3/8-16	UNC	,272	,312	,07	,323	,37	5/16-18	.0221	5/32	7/32
TR1652.76323	NL	5/16-18	UNC	7/16-14	UNC	,332	,375	,07	,385	,43	3/8-16	.0230	3/16	9/32
TR1652.76523	NL	5/16-24	UNF	7/16-14	UNC	,332	,375	,07	,385	,43	3/8-16	.0231	3/16	9/32
TR1652.76324	NL	3/8-16	UNC	1/2-13	UNC	,453	,500	,07	,510	,56	1/2-13	.0240	3/16	13/32
TR1652.76524	NL	3/8-24	UNF	1/2-13	UNC	,453	,500	,07	,510	,56	1/2-13	.0241	3/16	13/32
TR1652.76325	NL	7/16-14	UNC	9/16-12	UNC	,516	,562	,07	,572	,62	9/16-12	.0250	3/16	15/32



Order No.	Type	d <sub>1</sub> tol. 3B	Thread type d <sub>1</sub>	d <sub>2</sub> (mod.) class 2A	Thread type d <sub>2</sub>	Inst. tap drill size	l <sub>1</sub>	l <sub>4</sub> c'bor e dept h	C'sink hole size +0.01 0 -0.000	Inst. thread tap depth min.	Inst. thread tap size tol. 2B	Inst. tool ref. TR1702	Removal drill depth	Removal drill size
<b>TR1652.76525</b>	NL	7/16-20	UNF	9/16-12	UNC	,516	.562	,07	,572	,62	9/16-12	.0251	3/16	15/32
<b>TR1652.76326</b>	NL	1/2-13	UNC	5/8-11	UNC	,578	,625	,07	,635	,68	5/8-11	.0260	3/16	17/32
<b>TR1652.76526</b>	NL	1/2-20	UNF	5/8-11	UNC	,578	,625	,07	,635	,68	5/8-11	.0261	3/16	17/32



# Threaded Insert MS/NAS - Thinwall - 303 stainless steel - self-locking - MS/NAS grade

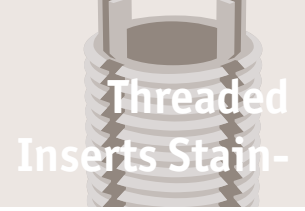

Threaded  
Inserts Stain-

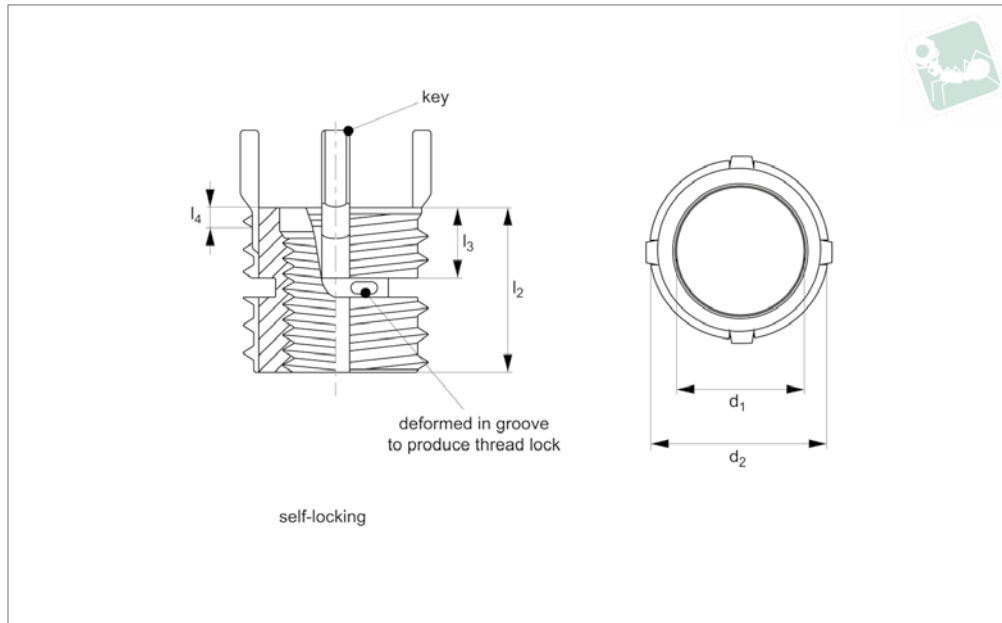

**TR1653**

THREADED INSERTS STAINLESS

## Material

Inserts - 303 CRES.  
Keys - 302 CRES.  
Passivated. Dry film lubrication on self-locking inserts only.

## Technical Notes

All dimensions in inches.  
Internal threads: to SAE AS8879.  
General tolerances -  
+/- 0,010 unless specified.  
Tap drill hole tolerances -

0,234 to 0,500 = +0,004/-0,001  
0,500 and over = +0,005/-0,001  
**SL** = Self-Locking type, deliberate deformity in thread produces self-affect once installed (see technical diagram).

## Tips

Order installation tool separately, as identified by „Inst. Tool ref.“ in table.

## Important Notes

Four locking keys on internal threads 5/16

and over. Two locking keys on internal threads smaller than 5/16.  
Installation (Inst.) drill size, counter sink, thread tap and thread depth as specified in table.  
Removal (Rem.) drill size and drill depth as specified in table.  
Perform to standards: MIL-I-45914A (MS51830 & NAS1394)

Order No.	Type	d <sub>1</sub> tol. 3B	Thre ad type d <sub>1</sub>	d <sub>2</sub> (mod.) class 2A	Thre ad type d <sub>2</sub>	Inst. tap drill size	l <sub>1</sub>	l <sub>3</sub> ±0.30 c'bore	l <sub>4</sub> depth	C'sink hole size +0.0 10 - 0.000	Inst. thread tap depth min.	Inst. thread tap size tol. 2B	Inst. tool ref. TR1702	Removal drill depth	Removal drill size
TR1653.77321	SL	10-24	UNC	5/16-18	UNC	,272	,312	.22	,07	,323	,37	5/16-18	.0210	5/32	7/32
TR1653.77521	SL	10-32	UNF	5/16-18	UNC	,272	,312	.22	,07	,323	,37	5/16-18	.0211	5/32	7/32
TR1653.77322	SL	1/4-20	UNC	3/8-16	UNC	,332	,375	.22	,07	,385	,43	3/8-16	.0220	3/16	9/32
TR1653.77522	SL	1/4-28	UNF	3/8-16	UNC	,332	,375	.22	,07	,385	,43	3/8-16	.0221	3/16	9/32
TR1653.77323	SL	5/16-18	UNC	7/16-14	UNC	,397	,437	.22	,07	,447	,50	7/16-14	.0230	3/16	11/32
TR1653.77523	SL	5/16-24	UNF	7/16-14	UNC	,397	,437	.22	,07	,447	,50	7/16-14	.0231	3/16	11/32
TR1653.77324	SL	3/8-16	UNC	1/2-13	UNC	,453	,500	.24	,07	,510	,56	1/2-13	.0240	3/16	13/32
TR1653.77524	SL	3/8-24	UNF	1/2-13	UNC	,453	,500	.24	,07	,510	,56	1/2-13	.0241	3/16	13/32
TR1653.77325	SL	7/16-14	UNC	9/16-12	UNC	,516	,562	.27	,07	,572	,62	9/16-12	.0250	3/16	15/32

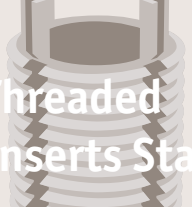

THREADED INSERTS STAINLESS

Order No.	Type	d <sub>1</sub> tol. 3B	Thre ad type d <sub>1</sub>	d <sub>2</sub> (mod.) class 2A	Thre ad type d <sub>2</sub>	Inst. tap drill size	l <sub>1</sub>	l <sub>3</sub> ±0.30	l <sub>4</sub> c'bore depth	C'sink hole size +0.0 10 - 0.000	Inst. thread tap depth min.	Inst. thread tap size tol. 2B	Inst. tool ref. TR1702	Removal drill depth	Removal drill size
<b>TR1653.77525</b>	SL	7/ 16- 20	UNF	9/16- 12	UNC	,516	.562	.27	,07	,572	,62	9/16-12	.0251	3/16	15/32
<b>TR1653.77326</b>	SL	1/2- 13	UNC	5/8- 11	UNC	,578	,625	.28	,07	,635	,68	5/8-11	.0260	3/16	17/32
<b>TR1653.77526</b>	SL	1/2- 20	UNF	5/8- 11	UNC	,578	,625	.28	,07	,635	,68	5/8-11	.0261	3/16	17/32





# Blind Threaded Insert - Thinwall - 303 stainless steel - non-locking

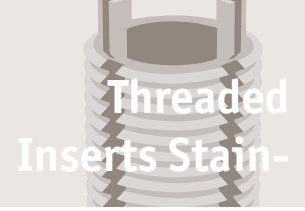

Threaded  
Inserts Stain-

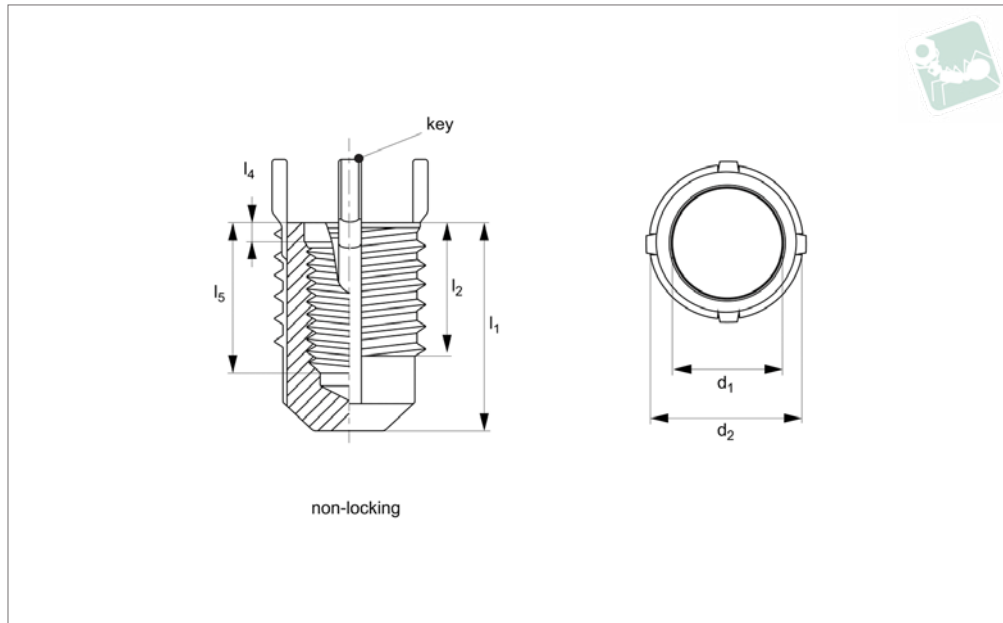

**TR1672**

THREADED INSERTS STAINLESS

### Material

Inserts - A303 CRES.  
Keys - 302 CRES.  
Passivated. Dry film lubrication on self-locking inserts only.

### Technical Notes

All dimensions in inches.  
Internal threads: to SAE AS8879.  
General tolerances -  
+/- 0,010 unless specified.

Tap drill hole tolerances -  
0,234 to 0,500 = +0,004/-0,001  
0,500 and over = +0,005/-0,001  
**NL** = Non-Locking type.

### Tips

Order installation tool separately, as identified by „Inst. Tool ref.“ in table.

### Important Notes

Four locking keys on internal threads 5/16

and over. Two locking keys on internal threads smaller than 5/16.  
Installation (Inst.) drill size, counter sink, thread tap and thread depth as specified in table.  
Removal (Rem.) drill size and drill depth as specified in table.  
Perform to standards: MIL-I-45914A

Order No.	Type	d <sub>1</sub> tol. 3B	Thre ad type d <sub>1</sub>	d <sub>2</sub> (mod.) class 2A	Thre ad type d <sub>2</sub>	Inst. tap drill size	l <sub>1</sub>	l <sub>2</sub>	l <sub>4</sub> c'bore depth	l <sub>5</sub>	Inst. c'sink hole size +0.010  -0.000	Inst. thread tap depth min.	Inst. thread tap size class 2B	Inst. tool ref. TR1702	Removal drill depth	Remo val drill size
TR1672.83321	NL	10-24	UNC	5/16-18	UNC	,272	,50	,31	,07	,31	,323	,37	5/16-18	.0210	5/32	7/32
TR1672.83521	NL	10-32	UNF	5/16-18	UNC	,272	,50	,31	,07	,31	,323	,37	5/16-18	.0210	5/32	7/32
TR1672.83322	NL	1/4-20	UNC	3/8-16	UNC	,332	,62	,37	,07	,37	,385	,43	3/8-16	.0220	3/16	9/32
TR1672.83522	NL	1/4-28	UNF	3/8-16	UNC	,332	,62	,37	,07	,37	,385	,43	3/8-16	.0220	3/16	9/32
TR1672.83323	NL	5/16-18	UNC	7/16-14	UNC	,397	,75	,43	,07	,43	,447	,50	7/16-14	.0230	3/16	11/32
TR1672.83523	NL	5/16-18	UNF	7/16-14	UNC	,397	,75	,43	,07	,43	,447	,50	7/16-14	.0230	3/16	11/32
TR1672.83324	NL	3/8-16	UNC	1/2-13	UNC	,453	,81	,50	,07	,50	,510	,56	1/2-13	.0240	3/16	13/32
TR1672.83524	NL	3/8-24	UNF	1/2-13	UNC	,453	,81	,50	,07	,50	,510	,56	1/2-13	.0240	3/16	13/32
TR1672.83325	NL	7/16-14	UNC	9/16-12	UNC	,516	,87	,56	,07	,56	,572	,62	9/16-12	.0250	3/16	15/32



Order No.	Type	d <sub>1</sub> tol. 3B	Thre ad type d <sub>1</sub>	d <sub>2</sub> (mod.) class 2A	Thre ad type d <sub>2</sub>	Inst. tap drill size	l <sub>1</sub>	l <sub>2</sub>	l <sub>4</sub> c'bore depth	l <sub>5</sub>	Inst. c'sink hole size +0.010  -0.000	Inst. thread tap depth min.	Inst. thread tap size class 2B	Inst. tool ref. TR1702	Removal drill depth	Remo val drill size
<b>TR1672.83525</b>	NL	7/ 16- 20	UNF	9/ 16- 12	UNC	,516	,87	,56	,07	,56	,572	,62	9/16-12	.0250	3/16	15/32
<b>TR1672.83326</b>	NL	1/2- 13	UNC	5/8- 11	UNC	,578	1.06	,62	,07	,62	,635	,68	5/8-11	.0260	3/16	17/32
<b>TR1672.83526</b>	NL	1/2- 20	UNF	5/8- 11	UNC	,578	1.06	,62	,07	,62	,635	,68	5/8-11	.0260	3/16	17/32



# Blind Threaded Insert - Thinwall - 303 stainless steel - self-locking

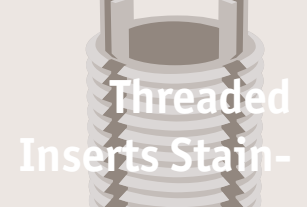

Threaded  
Inserts Stain-

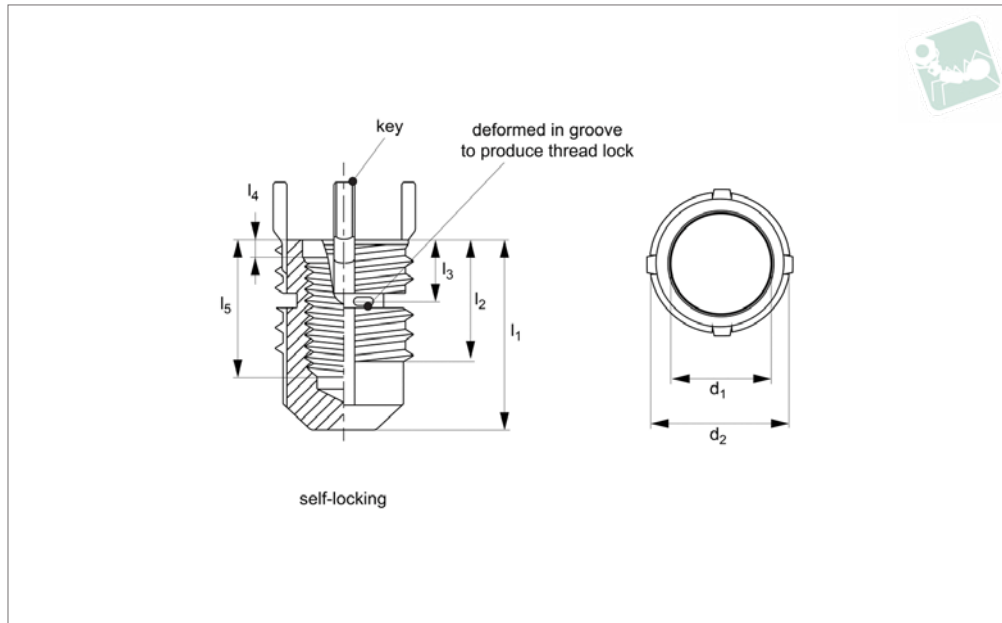

**TR1673**

THREADED INSERTS STAINLESS

### Material

Inserts - A303 CRES.  
Keys - 302 CRES.  
Passivated. Dry film lubrication on self-locking inserts only.

### Technical Notes

All dimensions in inches.  
Internal threads: to SAE AS8879.  
General tolerances -  
+/- 0,010 unless specified.

### Tap drill hole tolerances -

0,234 to 0,500 = +0,004/-0,001  
0,500 and over = +0,005/-0,001  
**SL** = Self-Locking type, deliberate deformity in thread produces self-affect once installed (see technical diagram).

### Tips

Order installation tool separately, as identified by „Inst. Tool ref.“ in table.

### Important Notes

Four locking keys on internal threads 5/16 and over. Two locking keys on internal threads smaller than 5/16.  
Installation (Inst.) drill size, counter sink, thread tap and thread depth as specified in table.  
Removal (Rem.) drill size and drill depth as specified in table.  
Perform to standards: MIL-I-45914A

Order No.	Type	d <sub>1</sub> tol. 3B	Thre ad type d <sub>1</sub>	d <sub>2</sub> (mod.) class 2A	Thre ad type d <sub>2</sub>	Inst. tap drill size	l <sub>1</sub>	l <sub>2</sub>	l <sub>3</sub> ±0.0 30	l <sub>4</sub> c'bore depth	l <sub>5</sub>	Inst. c'sink hole size +0.010  -0.000	Inst. thread tap depth min.	Inst. thread tap size class 2B	Inst. tool ref. TR1702	Removal drill depth	Rem oval drill size
TR1673.84321	SL	10-24	UNC	5/16-18	UNC	,272	,50	,31	,22	,07	,31	,323	,37	5/16-18	.0210	5/32	7/32
TR1673.84521	SL	10-32	UNF	5/16-18	UNC	,272	,50	,31	,22	,07	,31	,323	,37	5/16-18	.0210	5/32	7/32
TR1673.84322	SL	1/4-20	UNC	3/8-16	UNC	,332	,62	,37	,22	,07	,37	,385	,43	3/8-16	.0220	3/16	9/32
TR1673.84522	SL	1/4-28	UNF	3/8-16	UNC	,332	,62	,37	,22	,07	,37	,385	,43	3/8-16	.0220	3/16	9/32
TR1673.84323	SL	5/16-18	UNC	7/16-14	UNC	,397	,75	,43	,22	,07	,43	,447	,50	7/16-14	.0230	3/16	11/32
TR1673.84523	SL	5/16-18	UNF	7/16-14	UNC	,397	,75	,43	,22	,07	,43	,447	,50	7/16-14	.0230	3/16	11/32
TR1673.84324	SL	3/8-16	UNC	1/2-13	UNC	,453	,81	,50	,24	,07	,50	,510	,56	1/2-13	.0240	3/16	13/32
TR1673.84524	SL	3/8-24	UNF	1/2-13	UNC	,453	,81	,50	,24	,07	,50	,510	,56	1/2-13	.0240	3/16	13/32
TR1673.84325	SL	7/16-14	UNC	9/16-12	UNC	,516	,87	,56	,27	,07	,56	,572	,62	9/16-12	.0250	3/16	15/32



Order No.	Type	d <sub>1</sub> tol. 3B	Thre ad type d <sub>1</sub>	d <sub>2</sub> (mod.) class 2A	Thre ad type d <sub>2</sub>	Inst. tap drill size	l <sub>1</sub>	l <sub>2</sub>	l <sub>3</sub> ±0.0 30	l <sub>4</sub> c'bore depth	l <sub>5</sub>	Inst. c'sink hole size +0.010  -0.000	Inst. thread tap depth min.	Inst. thread tap size class 2B	Inst. tool ref. TR1702	Removal drill depth	Rem oval drill size
TR1673.84525	SL	7/ 16- 20	UNF	9/ 16- 12	UNC	,516	,87	,56	,27	,07	,56	,572	,62	9/16- 12	.0250	3/16	15/ 32
TR1673.84326	SL	1/2- 13	UNC	5/8- 11	UNC	,578	1.06	,62	,28	,07	,62	,635	,68	5/8-11	.0260	3/16	17/ 32
TR1673.84526	SL	1/2- 20	UNF	5/8- 11	UNC	,578	1.06	,62	,28	,07	,62	,635	,68	5/8-11	.0260	3/16	17/ 32



# Threaded Insert - Metric

heavy duty - stainless steel

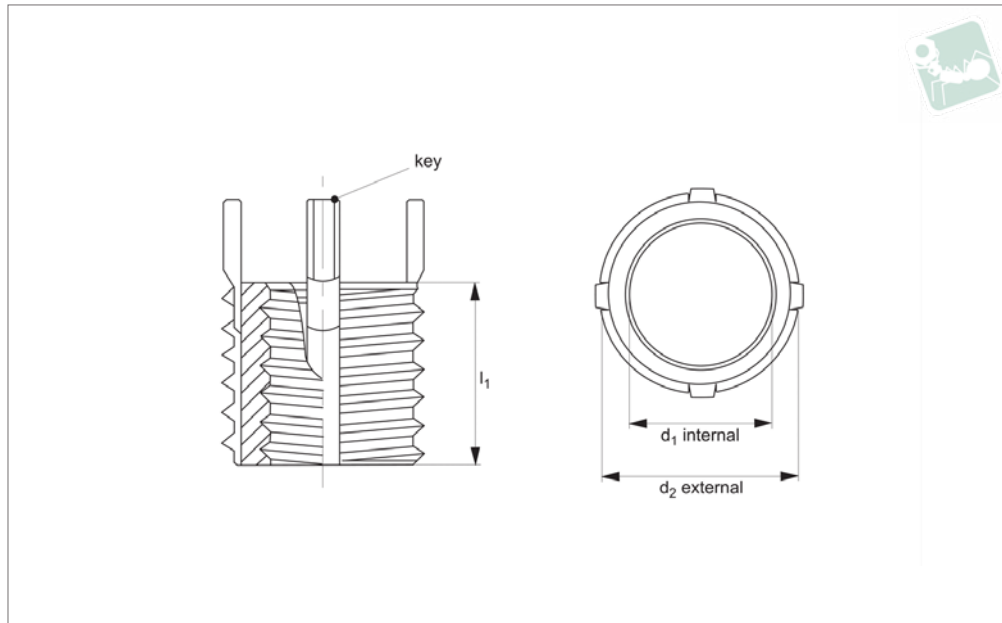
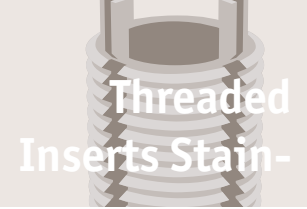

**TR1515**

THREADED INSERTS STAINLESS

### Material

Inserts: stainless steel (AISI 303) or equivalent. Passivated.

Keys: stainless steel (302 CRES) or equivalent. Passivated.

### Technical Notes

#### General tolerances:

±0,25, unless specified.

### Tap drill hole tolerances:

6,9 to 10,8 = +0,10/-0,025.

12,8 and over = +0,13/-0,025.

### Tips

Order installation tool separately, as identified by „Inst. tool ref.“ in table.

### Important Notes

Four locking keys on internal threads M 8 and over. Two locking keys on internal threads smaller than M 8.

Installation (Inst.) drill size, countersink, thread tap and thread depth as specified in table.

Removal drill size and drill depth as speci-

Order No.	Int. d <sub>1</sub> tol. 6H	Int. thread type d <sub>1</sub>	Ext. d <sub>2</sub> tol. 6g	Ext. thread type d <sub>2</sub>	l <sub>1</sub>	Inst. tool ref. 22062	Inst. tap drill size	Inst. c'sink dia. ±0.25   ± 0.000	Inst. thread tap tol. 6H	Inst. thread depth min.	Removal drill size	Removal drill depth
TR1515.66363	M 4x0,70	Coarse	M 8x1,25	Coarse	8	.W0630	6,9	8,3	M 8x1,25	9,5	5,5	4,0
TR1515.66364	M 5x0,80	Coarse	M10x1,25	Fine	10	.W0640	8,8	10,3	M10x1,25	12,5	7,5	4,8
TR1515.66365	M 6x1,00	Coarse	M12x1,25	Fine	12	.W0650	10,8	12,3	M12x1,25	14,5	9,5	4,8
TR1515.66366	M 8x1,25	Coarse	M14x1,50	Fine	14	.W0660	12,8	14,3	M14x1,50	16,5	11,5	4,8
TR1515.66566	M 8x1,00	Fine	M14x1,50	Fine	14	.W0660	12,8	14,3	M14x1,50	16,5	11,5	4,8
TR1515.66367	M10x1,50	Coarse	M16x1,50	Fine	16	.W0670	14,8	16,3	M16x1,50	18,5	13,5	4,8
TR1515.66567	M10x1,25	Fine	M16x1,50	Fine	16	.W0670	14,8	16,3	M16x1,50	18,5	13,5	4,8
TR1515.66369	M12x1,75	Coarse	M18x1,50	Fine	18	.W0690	16,8	18,3	M18x1,50	20,5	15,5	4,8
TR1515.66569	M12x1,25	Fine	M18x1,50	Fine	18	.W0690	16,8	18,3	M18x1,50	20,5	15,5	4,8
TR1515.66370	M14x2,00	Coarse	M20x1,50	Fine	20	.W0700	18,8	20,3	M20x1,50	22,5	17,5	4,8
TR1515.66570	M14x1,50	Fine	M20x1,50	Fine	20	.W0700	18,8	20,3	M20x1,50	22,5	17,5	4,8
TR1515.66371	M16x2,00	Coarse	M22x1,50	Fine	22	.W0710	20,5	22,3	M22x1,50	24,5	17,8	6,4
TR1515.66571	M16x1,50	Fine	M22x1,50	Fine	22	.W0710	20,5	22,3	M22x1,50	24,5	17,8	6,4
TR1515.66572	M18x1,50	Fine	M24x1,50	Fine	24	.W0720	22,5	24,3	M24x1,50	26,5	19,8	6,4
TR1515.66373	M20x2,50	Coarse	M30x2,00	Non-Std	30	.W0730	28,0	30,3	M30x2,00	34,5	25,8	6,4
TR1515.66573	M20x1,50	Fine	M30x2,00	Non-Std	30	.W0730	28,0	30,3	M30x2,00	34,5	25,8	6,4
TR1515.66574	M22x1,50	Fine	M32x2,00	Non-Std	32	.W0740	30,0	32,3	M32x2,00	36,5	27,8	6,4
TR1515.66375	M24x3,00	Coarse	M33x2,00	Non-Std	33	.W0750	31,0	33,3	M33x2,00	37,5	28,8	6,4
TR1515.66575	M24x2,00	Fine	M33x2,00	Non-Std	33	.W0750	31,0	33,3	M33x2,00	37,5	28,8	6,4



TR1530

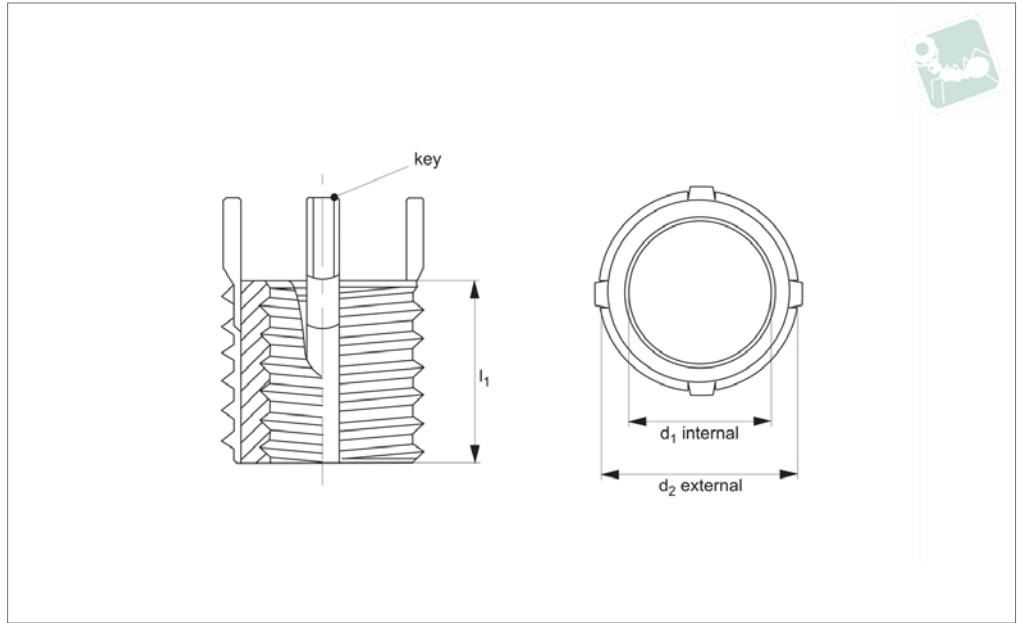

**Material**

Inserts: stainless steel (AISI 303) or equivalent. Passivated.

Keys: stainless steel (302 CRES) or equivalent. Passivated.

**Technical Notes**

**General tolerances:**

±0,010" unless specified.

**Tap drill hole tolerances:**

0,234 to 0,500 = +0,004/-0,001"  
0,500 and over = +0,005/-0,001"

**Tips**

Order installation tool separately, as identified by „Inst. Tool ref.“ in table.

**Important Notes**

Four locking keys on internal threads M8 and over. Two locking keys on internal

threads smaller than M8.

Installation (Inst.) drill size, countersink, thread tap and thread depth as specified in table.

Removal drill size and drill depth as specified in table.

**Internal thread in metric. External thread in inches.**

Order No.	Int. d <sub>1</sub> tol. 6H	Int. thread type d <sub>1</sub>	Ext. d <sub>2</sub> tol. 2A	Ext. thread type d <sub>2</sub>	l <sub>1</sub>	Inst. tool ref. 22064	Inst. tap drill size	Inst. c'sink dia. +0.010 - 0.000	Inst. thread tap tol. 2B	Inst. thread depth min.	Removal drill size	Removal drill depth
TR1530.66643	M 6x1,00	Coarse	3/8"-16	UNC	0,3	.W0430	21/64"	0,38	3/8"-16	0,37	9/32"	1/8"
TR1530.66644	M 8x1,25	Coarse	1/2"-13	UNC	0,4	.W0440	29/64"	0,51	1/2"-13	0,50	13/32"	3/16"
TR1530.66645	M10x1,50	Coarse	5/8"-11	UNC	0,5	.W0450	37/64"	0,63	5/8"-11	0,56	17/32"	3/16"
TR1530.66647	M12x1,75	Coarse	3/4"-16	UNF	0,6	.W0470	45/64"	0,76	3/4"-16	0,68	21/32"	3/16"
TR1530.66648	M14x2,00	Coarse	7/8"-14	UNF	0,8	.W0480	53/64"	0,88	7/8"-14	0,94	25/32"	5/16"
TR1530.66649	M16x2,00	Coarse	1"-12	UNF	0,9	.W0490	15/16"	1,02	1"-12	1,00	27/32"	5/16"



# Threaded Insert - Inch heavy duty - stainless steel

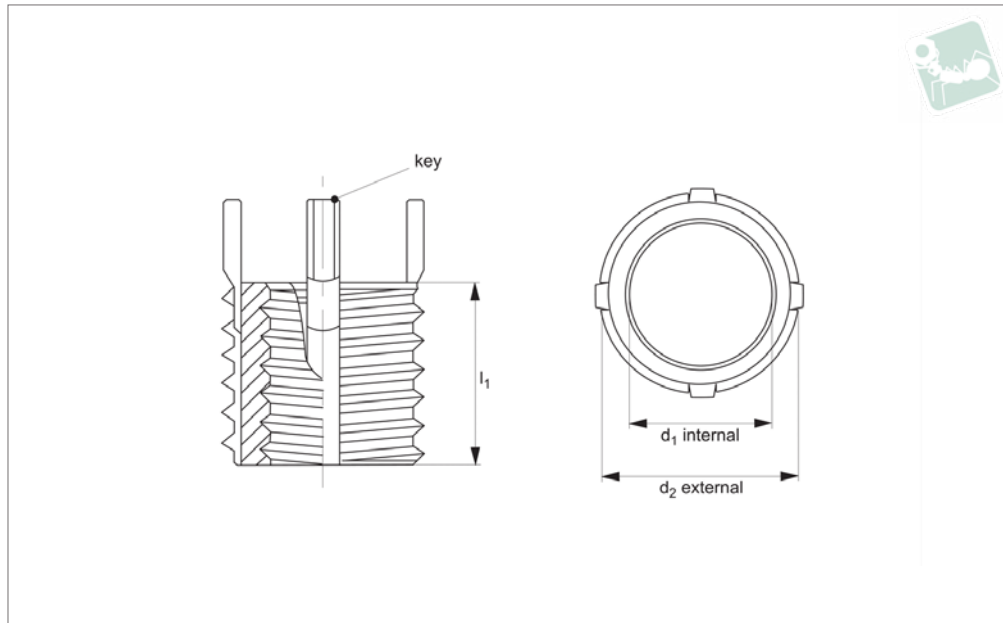
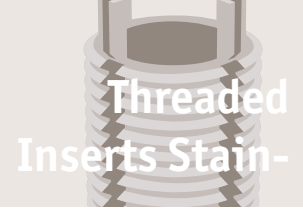

## TR1565

THREADED INSERTS STAINLESS

### Material

Inserts: stainless steel (AISI 303) or equivalent. Passivated.

Keys: stainless steel (302 CRES) or equivalent. Passivated.

### Technical Notes

#### General tolerances:

± 0,010" unless specified.

#### Tap drill hole tolerances:

0,234 to 0,500 = +0,004/-0,001".

0,500 and over = +0,005/-0,001".

### Tips

Order installation tool separately, as identified by „Inst. tool ref.“ in table.

### Important Notes

Four locking keys on internal threads 5/16" and over. Two locking keys on internal

threads smaller than 5/16".

Installation (Inst.) drill size, countersink, thread tap and thread depth as specified in table.

Removal drill size and drill depth as specified in table.

**All dimensions in inches.**

Order No.	Int. d <sub>1</sub> tol. 2B	Int. thread type d <sub>1</sub>	Ext. d <sub>2</sub> tol. 2A	Ext. thread type d <sub>2</sub>	l <sub>1</sub>	Inst. tool ref. 22056	Inst. tap drill size	Inst. c'sink dia. +0.010 - 0.000	Inst. thread tap tol. 2B	Inst. thread depth min.	Removal drill size	Removal drill depth
TR1565.66300	8-32	UNC	5/16"-18	UNC	0,31	.W0000	17/64"	0,32	5/16"-18	0,37	7/32"	1/8"
TR1565.66301	10-24	UNC	3/8"-16	UNC	0,31	.W0010	21/64"	0,38	3/8"-16	0,37	9/32"	1/8"
TR1565.66501	10-32	UNF	3/8"-16	UNC	0,31	.W0010	21/64"	0,38	3/8"-16	0,37	9/32"	1/8"
TR1565.66302	1/4"-20	UNC	7/16"-14	UNC	0,37	.W0020	25/64"	0,44	7/16"-14	0,43	11/32"	3/16"
TR1565.66502	1/4"-28	UNF	7/16"-14	UNC	0,37	.W0020	25/64"	0,44	7/16"-14	0,43	11/32"	3/16"
TR1565.66303	5/16"-18	UNC	1/2"-13	UNC	0,43	.W0030	29/64"	0,51	1/2"-13	0,50	13/32"	3/16"
TR1565.66503	5/16"-24	UNF	1/2"-13	UNC	0,43	.W0030	29/64"	0,51	1/2"-13	0,50	13/32"	3/16"
TR1565.66304	3/8"-16	UNC	9/16"-12	UNC	0,50	.W0040	33/64"	0,57	9/16"-12	0,56	15/32"	3/16"
TR1565.66504	3/8"-24	UNF	9/16"-12	UNC	0,50	.W0040	33/64"	0,57	9/16"-12	0,56	15/32"	3/16"
TR1565.66305	7/16"-14	UNC	5/8"-11	UNC	0,62	.W0050	37/64"	0,63	5/8"-11	0,68	17/32"	3/16"
TR1565.66505	7/16"-20	UNF	5/8"-11	UNC	0,62	.W0050	37/64"	0,63	5/8"-11	0,68	17/32"	3/16"
TR1565.66306	1/2"-13	UNC	3/4"-16	UNF	0,62	.W0060	45/64"	0,76	3/4"-16	0,68	21/32"	3/16"
TR1565.66506	1/2"-20	UNF	3/4"-16	UNF	0,62	.W0060	45/64"	0,76	3/4"-16	0,68	21/32"	3/16"
TR1565.66307	9/16"-12	UNC	3/4"-16	UNF	0,81	.W0070	45-64"	0,76	3/4"-16	0,94	21/32"	3/16"
TR1565.66507	9/16"-18	UNF	3/4"-16	UNF	0,81	.W0070	45-64"	0,76	3/4"-16	0,94	21/32"	3/16"
TR1565.66308	5/8"-11	UNC	7/8"-14	UNF	0,87	.W0080	53/64"	0,88	7/8"-14	1,00	25/32"	5/16"
TR1565.66508	5/8"-18	UNF	7/8"-14	UNF	0,87	.W0080	53/64"	0,88	7/8"-14	1,00	25/32"	5/16"
TR1565.66309	3/4"-10	UNC	1-1/8"-12	UNF	1,12	.W0090	1-1/16"	1,14	1-1/8"-12	1,31	31/32"	5/16"
TR1565.66509	3/4"-16	UNF	1-1/8"-12	UNF	1,12	.W0090	1-1/16"	1,14	1-1/8"-12	1,31	31/32"	5/16"
TR1565.66310	7/8"-9	UNC	1-1/4"-12	UNF	1,25	.W0100	1-3/16"	1,27	1-1/4"-12	1,44	1-3/32"	5/16"
TR1565.66510	7/8"-14	UNF	1-1/4"-12	UNF	1,25	.W0100	1-3/16"	1,27	1-1/4"-12	1,44	1-3/32"	5/16"
TR1565.66311	1"-8	UNC	1-3/8"-12	UNF	1,37	.W0110	1-5/16"	1,39	1-3/8"-12	1,56	1-7/32"	5/16"
TR1565.66511	1"-12	UNF	1-3/8"-12	UNF	1,37	.W0110	1-5/16"	1,39	1-3/8"-12	1,56	1-7/32"	5/16"



TR1604

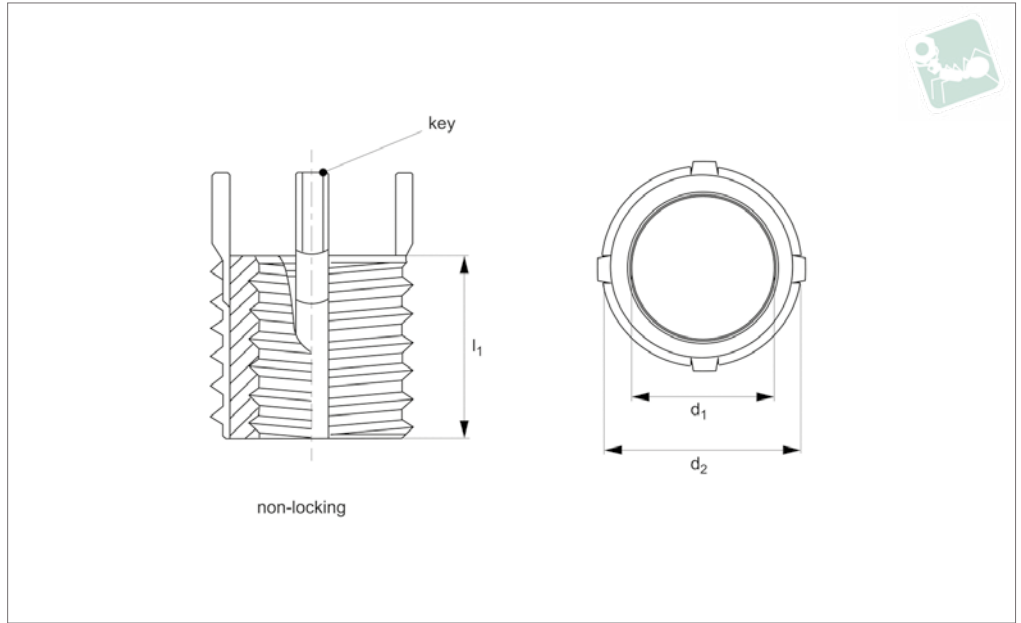

**Material**

Inserts - 303 CRES.  
Keys - 302 CRES.  
Passivated. Dry film lubrication on self-locking inserts only.

**Technical Notes**

All dimensions in millimetres.  
Internal threads: to Fed. Std. H28/21, MJ Form

**General tolerances -**

+/- 0,25mm, unless specified.  
Tap drill hole tolerances -  
6,9 to 10,8 = +0,100/-0,025  
12,8 and over = +0,130/-0,025  
**NL** = Non-Locking type.

**Tips**

Order installation tool separately, as identified by „Inst. Tool ref.“ in table.

**Important Notes**

Four locking keys on internal threads M6 and over. Two locking keys on internal threads smaller than M6.  
Installation (Inst.) drill size, counter sink, thread tap and thread depth as specified in table.  
Removal (Rem.) drill size and drill depth as specified in table.

Order No.	Type	d <sub>1</sub> tol. 4H type 5H	Thread d <sub>1</sub> type	d <sub>2</sub> tol. 4h type	Thread d <sub>2</sub> type	l <sub>1</sub>	l <sub>4</sub> c'bore depth	C'bore hole dia. +0.25  -0.00	Inst. tap drill size	Inst. thread tap tol. 6H	Inst. thread tap depth min.	Inst. tool ref. TR1715	Removal drill size	Removal drill depth
TR1604.76363	NL	M 4x0, 7	Coars e	M 8x1, 25	Coars e	8.0	1.27	8.25	6.90	M 8x1,25	9.5	.0630	5.50	4.00
TR1604.76364	NL	M 5x0, 8	Coars e	M10 x1,2 5	Fine	10.0	1.27	10.25	8.80	M10x1 ,25	12.5	.0640	7.50	4.75
TR1604.76365	NL	M 6x1, 0	Coars e	M12 x1,2 5	Fine	12.0	1.78	12.25	10.80	M12x1 ,25	14.5	.0650	9.50	4.75
TR1604.76366	NL	M 8x1, 25	Coars e	M14 x1,5	Fine	14.0	1.78	14.25	12.80	M14x1 ,5	16.5	.0660	11.50	4.75
TR1604.76566	NL	M 8x1, 0	Fine	M14 x1,5	Fine	14.0	1.78	14.25	12.80	M14x1 ,5	16.5	.0660	11.50	4.75
TR1604.76367	NL	M10 x1,5	Coars e	M16 x1,5	Fine	16.0	2.29	16.25	14.75	M16x1 ,5	18.5	.0670	13.50	4.75
TR1604.76567	NL	M10 x1,2 5	Fine	M16 x1,5	Fine	16.0	2.29	16.25	14.75	M16x1 ,5	18.5	.0670	13.50	4.75
TR1604.76369	NL	M12 x1,7 5	Coars e	M18 x1,5	Fine	18.0	2.29	18.25	16.75	M18x1 ,5	20.5	.0690	15.50	4.75





# Threaded Insert MS/NAS - H Duty - 303 stainless steel - non-locking - MS/NAS grade

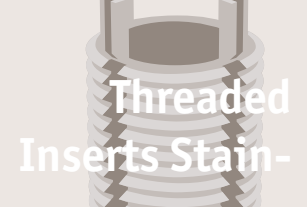

Order No.	Type	d <sub>1</sub> tol. 4H 5H	Thread type d <sub>1</sub>	d <sub>2</sub> tol. 4h	Thread type d <sub>2</sub>	l <sub>1</sub>	l <sub>4</sub> c'bore depth	C'bore hole dia. +0.25  -0.00	Inst. tap drill size	Inst. thread tap tol. 6H	Inst. thread tap depth min.	Inst. tool ref. TR1715	Removal drill size	Removal drill depth
TR1604.76569	NL	M12 x1,2 5	Fine	M18 x1,5	Fine	18.0	2.29	18.25	16.75	M18x1 ,5	20.5	.0690	15.50	4.75
TR1604.76370	NL	M14 x2,0	Coars e	M20 x1,5	Fine	20.0	2.79	20.25	18.75	M20x1 ,5	22.5	.0700	17.50	4.75
TR1604.76570	NL	M14 x1,5	Fine	M20 x1,5	Fine	20.0	2.79	20.25	18.75	M20x1 ,5	22.5	.0700	17.50	4.75
TR1604.76371	NL	M16 x2,0	Coars e	M22 x1,5	Fine	22.0	2.79	22.25	20.50	M22x1 ,5	24.5	.0710	17.75	6.35
TR1604.76571	NL	M16 x1,5	Fine	M22 x1,5	Fine	22.0	2.79	22.25	20.50	M22x1 ,5	24.5	.0710	17.75	6.35
TR1604.76572	NL	M18 x1,5	Fine	M24 x2,0	Fine	24.0	2.79	24.25	22.50	M24x2 ,0	28.5	.0720	19.75	6.35
TR1604.76373	NL	M20 x2,5	Coars e	M30 x2,0	Fine	30.0	2.79	30.25	28.00	M30x2 ,0	34.5	.0730	25.75	6.35
TR1604.76573	NL	M20 x1,5	Fine	M30 x2,0	Fine	30.0	2.79	30.25	28.00	M30x2 ,0	34.5	.0730	25.75	6.35
TR1604.76574	NL	M22 x1,5	Fine	M32 x2,0	Non- Std	32.0	2.79	32.25	30.00	M32x2 ,0	36.5	.0740	27.75	6.35
TR1604.76375	NL	M24 x3,0	Coars e	M33 x2,0	Non- Std	33.0	3.81	33.25	31.00	M33x2 ,0	37.5	.0750	28.75	6.35
TR1604.76575	NL	M24 x2,0	Fine	M33 x2,0	Non- Std	33.0	3.81	33.25	31.00	M33x2 ,0	37.5	.0750	28.75	6.35

THREADED INSERTS STAINLESS



**TR1605**

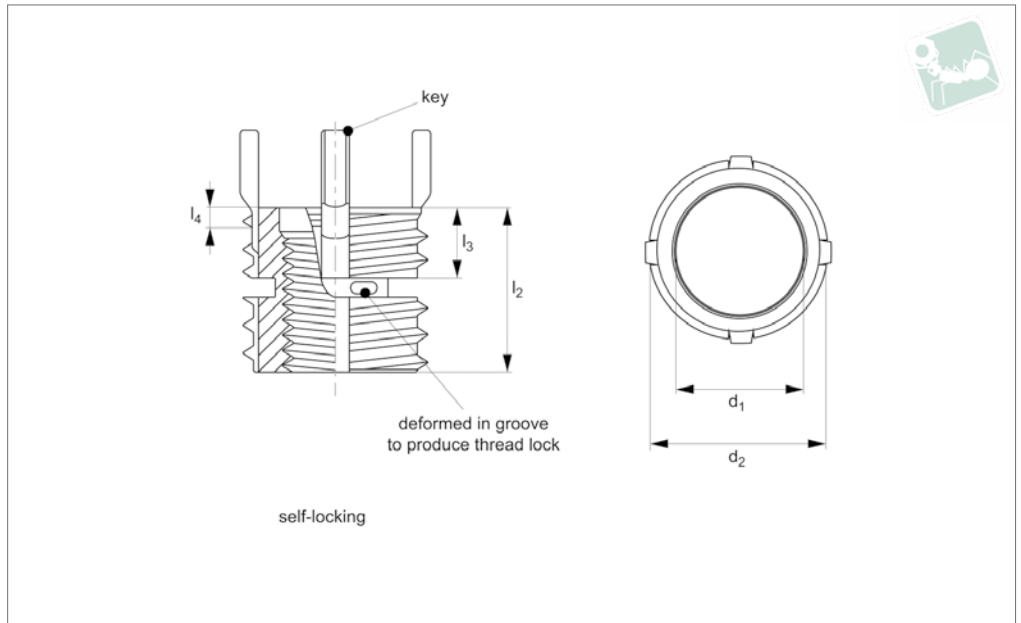

**Material**

Inserts - 303 CRES.  
Keys - 302 CRES.  
Passivated. Dry film lubrication on self-locking inserts only.

**Technical Notes**

All dimensions in millimetres.  
Internal threads: to Fed. Std. H28/21, MJ Form  
General tolerances -

+/- 0,25mm, unless specified.

Tap drill hole tolerances -  
6,9 to 10,8 = +0,100/-0,025  
12,8 and over = +0,130/-0,025

**SL** = Self-Locking type, deliberate deformity in thread produces self-affect once installed (see technical diagram).

**Tips**

Order installation tool separately, as identified by „Inst. Tool ref.“ in table.

**Important Notes**

Four locking keys on internal threads M6 and over. Two locking keys on internal threads smaller than M6.

Installation (Inst.) drill size, counter sink, thread tap and thread depth as specified in table.

Removal (Rem.) drill size and drill depth as specified in table.

Order No.	Type	d <sub>1</sub> tol. 5H	Thread type	d <sub>2</sub> tol. 4h	Thread type	l <sub>1</sub>	l <sub>3</sub> ±0.76	l <sub>4</sub> c'bor dept h	C'bore hole dia. +0.25 -0.00	Inst. tap drill size	Inst. thread tap tol. 6H	Inst. thread tap depth min.	Inst. tool ref. TR1715	Removal drill size	Removal drill depth
TR1605.77363	SL	M 4x0,7	Coars e	M 8x1,25	Coars e	8.0	5.00	1.27	8.25	6.90	M 8x1,25	9.5	.0630	5.50	4.00
TR1605.77364	SL	M 5x0,8	Coars e	M10 x1,25	Fine	10.0	5.50	1.27	10.25	8.80	M10x 1,25	12.5	.0640	7.50	4.75
TR1605.77365	SL	M 6x1,0	Coars e	M12 x1,25	Fine	12.0	6.46	1.78	12.25	10.80	M 2x1,25	14.5	.0650	9.50	4.75
TR1605.77366	SL	M 8x1,25	Coars e	M14 x1,5	Fine	14.0	6.46	1.78	14.25	12.80	M14x 1,5	16.5	.0660	11.50	4.75
TR1605.77566	SL	M 8x1,0	Fine	M14 x1,5	Fine	14.0	6.46	1.78	14.25	12.80	M14x 1,5	16.5	.0660	11.50	4.75
TR1605.77367	SL	M10 x1,5	Coars e	M16 x1,5	Fine	16.0	6.46	2.29	16.25	14.75	M16x 1,5	18.5	.0670	13.50	4.75
TR1605.77567	SL	M10 x1,25	Fine	M16 x1,5	Fine	16.0	6.46	2.29	16.25	14.75	M16x 1,5	18.5	.0670	13.50	4.75
TR1605.77369	SL	M12 x1,75	Coars e	M18 x1,5	Fine	18.0	7.23	2.29	18.25	16.75	M18x 1,5	20.5	.0690	15.50	4.75



# Threaded Insert MS/NAS - H Duty - 303 stainless steel - self-locking - MS/NAS grade

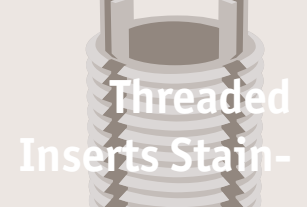

Order No.	Type	d <sub>1</sub> tol. 4H 5H	Thread type d <sub>1</sub>	d <sub>2</sub> tol. 4h	Thread type d <sub>2</sub>	l <sub>1</sub>	l <sub>3</sub> ±0.76	l <sub>4</sub> e	c'bor h	C'bore hole dia. +0.25 - 0.00	Inst. tap drill size	Inst. thread tap tol. 6H	Inst. thread tap depth min.	Inst. tool ref. TR1715	Removal drill size	Removal drill depth
TR1605.77569	SL	M12 x1,2 5	Fine	M18 x1,5	Fine	18.0	7.23	2.29	18.25	16.75	M18x 1,5	20.5	.0690	15.50	4.75	
TR1605.77370	SL	M14 x2,0	Coars e	M20 x1,5	Fine	20.0	7.73	2.79	20.25	18.75	M20x 1,5	22.5	.0700	17.50	4.75	
TR1605.77570	SL	M14 x1,5	Fine	M20 x1,5	Fine	20.0	7.73	2.79	20.25	18.75	M20x 1,5	22.5	.0700	17.50	4.75	
TR1605.77371	SL	M16 x2,0	Coars e	M22 x1,5	Fine	22.0	8.50	2.79	22.25	20.50	M22x 1,5	24.5	.0710	17.75	6.35	
TR1605.77571	SL	M16 x1,5	Fine	M22 x1,5	Fine	22.0	8.50	2.79	22.25	20.50	M22x 1,5	24.5	.0710	17.75	6.35	
TR1605.77572	SL	M18 x1,5	Fine	M24 x2,0	Fine	24.0	9.25	2.79	24.25	22.50	M24x 2,0	28.5	.0720	19.75	6.35	
TR1605.77373	SL	M20 x2,5	Coars e	M30 x2,0	Fine	30.0	12.5 1	2.79	30.25	28.00	M30x 2,0	34.5	.0730	25.75	6.35	
TR1605.77573	SL	M20 x1,5	Fine	M30 x2,0	Fine	30.0	12.5 1	2.79	30.25	28.00	M30x 2,0	34.5	.0730	25.75	6.35	
TR1605.77574	SL	M22 x1,5	Fine	M32 x2,0	Non- Std	32.0	12.5 1	2.79	32.25	30.00	M32x 2,0	36.5	.0740	27.75	6.35	
TR1605.77375	SL	M24 x3,0	Coars e	M33 x2,0	Non- Std	33.0	13.9 7	3.81	33.25	31.00	M33x 2,0	37.5	.0750	28.75	6.35	
TR1605.77575	SL	M24 x2,0	Fine	M33 x2,0	Non- Std	33.0	13.9 7	3.81	33.25	31.00	M33x 2,0	37.5	.0750	28.75	6.35	

THREADED INSERTS STAINLESS



## TR1654

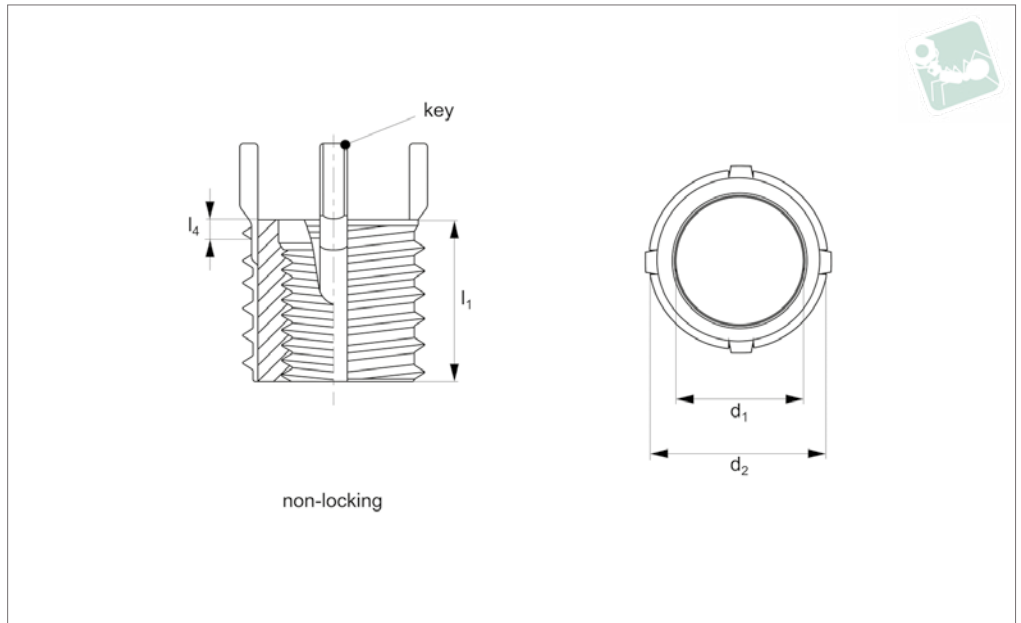

### Material

Inserts - 303 CRES.  
 Keys - 302 CRES.  
 Passivated. Dry film lubrication on self-locking inserts only.

### Technical Notes

All dimensions in inches.  
 Internal threads: to SAE AS8879.  
 General tolerances -  
 +/- 0,010 unless specified.

Tap drill hole tolerances -  
 0,234 to 0,500 = +0,004/-0,001  
 0,500 and over = +0,005/-0,001  
**NL** = Non-Locking type.

### Tips

Order installation tool separately, as identified by „Inst. Tool ref.“ in table.

### Important Notes

Four locking keys on internal threads 5/16

and over. Two locking keys on internal threads smaller than 5/16.  
 Installation (Inst.) drill size, counter sink, thread tap and thread depth as specified in table.  
 Removal (Rem.) drill size and drill depth as specified in table.  
 Perform to standards: MIL-I-45914A (MS51830 & NAS1394)

Order No.	Type	d <sub>1</sub> tol. 3B	Thread type d <sub>1</sub>	d <sub>2</sub> (mod.) class 2A	Thread type d <sub>2</sub>	l <sub>1</sub>	l <sub>4</sub> c'bore depth	Inst. c'sink hole size +0.010 -0.000	Inst. tap drill size	Inst. thread tap depth min.	Inst. thread tap size class B	Inst. tool ref. TR1705	Removal drill size	Removal drill depth
TR1654.76300	NL	8-32	UNC	5/16-18	UNC	,312	,04	,323	,272	,37	5/16-18	.0000	7/32	1/8
TR1654.76301	NL	10-24	UNC	3/8-16	UNC	,312	,07	,385	,332	,37	3/8-16	.0010	9/32	1/8
TR1654.76501	NL	10-32	UNF	3/8-16	UNC	,312	,07	,385	,332	,37	3/8-16	.0011	9/32	1/8
TR1654.76302	NL	1/4-20	UNC	7/16-14	UNC	,375	,07	,447	,397	,43	7/16-14	.0020	11/32	3/16
TR1654.76502	NL	1/4-28	UNF	7/16-14	UNC	,375	,07	,447	,397	,43	7/16-14	.0021	11/32	3/16
TR1654.76303	NL	5/16-18	UNC	1/2-13	UNC	,437	,07	,510	,453	,50	1/2-13	.0030	13/32	3/16
TR1654.76503	NL	5/16-24	UNF	1/2-13	UNC	,437	,07	,510	,453	,50	1/2-13	.0031	13/32	3/16
TR1654.76304	NL	3/8-16	UNC	9/16-12	UNC	,500	,07	,572	,516	,56	9-16-12	.0040	15/32	3/16
TR1654.76504	NL	3/8-24	UNF	9/16-12	UNC	,500	,07	,572	,516	,56	9-16-12	.0041	15/32	3/16
TR1654.76305	NL	7/16-14	UNC	5/8-11	UNC	,625	,10	,635	,578	,68	5/8-11	.0050	17/32	3/16



# Threaded Insert MS/NAS - H Duty - 303 stainless steel - non-locking - MS/NAS grade

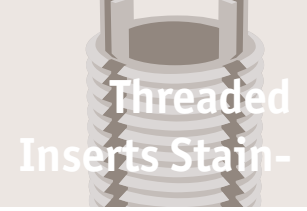

Order No.	Type	d <sub>1</sub> tol. 3B	Thread type d <sub>1</sub>	d <sub>2</sub> (mod.) class 2A	Thread type d <sub>2</sub>	l <sub>1</sub>	l <sub>4</sub> c'bore depth	Inst. c'sink hole size +0.010 - 0.000	Inst. tap drill size	Inst. thread tap depth min.	Inst. thread tap size class B	Inst. tool ref. TR1705	Removal drill size	Removal drill depth
TR1654.76505	NL	7/ 16- 20	UNF	5/8- 11	UNC	,625	,10	,635	,578	,68	5/8-11	.0051	17/32	3/16
TR1654.76306	NL	1/2- 13	UNC	11/ 16- 11NS	UNS	,688	,10	,700	,641	,75	11/16- 11NS	.0060	19/32	3/16
TR1654.76506	NL	1/2- 20	UNF	11/ 16- 11NS	UNS	,688	,10	,700	,641	,75	11/16- 11NS	.0061	19/32	3/16
TR1654.76307	NL	9/ 16- 12	UNC	13/ 16-16	UNF	,812	,10	,822	,766	,94	13/16-16	.0070	23/32	3/16
TR1654.76507	NL	9/ 16- 18	UNF	13/ 16-16	UNF	,812	,10	,822	,766	,94	13/16-16	.0071	23/32	3/16
TR1654.76308	NL	5/8- 11	UNC	7/8- 14	UNF	,875	,10	,885	,828	1.00	7/8-14	.0080	25/32	3/16
TR1654.76508	NL	5/8- 18	UNF	7/8- 14	UNF	,875	,10	,885	,828	1.00	7/8-14	.0081	25/32	3/16
TR1654.76309	NL	3/4- 10	UNC	1-1/ 8-12	UNF	1.12 5	,10	1.145	1.062	1.31	1-1/8-12	.0090	31/32	5/16
TR1654.76509	NL	3/4- 16	UNF	1-1/ 8-12	UNF	1.12 5	,10	1.145	1.062	1.31	1-1/8-12	.0091	31/32	5/16
TR1654.76310	NL	7/8- 9	UNC	1-1/ 4-12	UNF	1.25 0	,10	1.270	1.187	1.44	1-1/4-12	.0100	1-3/32	5/16
TR1654.76510	NL	7/8- 14	UNF	1-1/ 4-12	UNF	1.25 0	,10	1.270	1.187	1.44	1-1/4-12	.0101	1-3/32	5/16
TR1654.76311	NL	1-8	UNC	1-3/ 8-12	UNF	1.37 5	,10	1.395	1.312	1.56	1-3/8-12	.0110	1-7/32	5/16
TR1654.76511	NL	1-12	UNF	1-3/ 8-12	UNF	1.37 5	,10	1.395	1.312	1.56	1-3/8-12	.0111	1-7/32	5/16

THREADED INSERTS STAINLESS



## TR1655

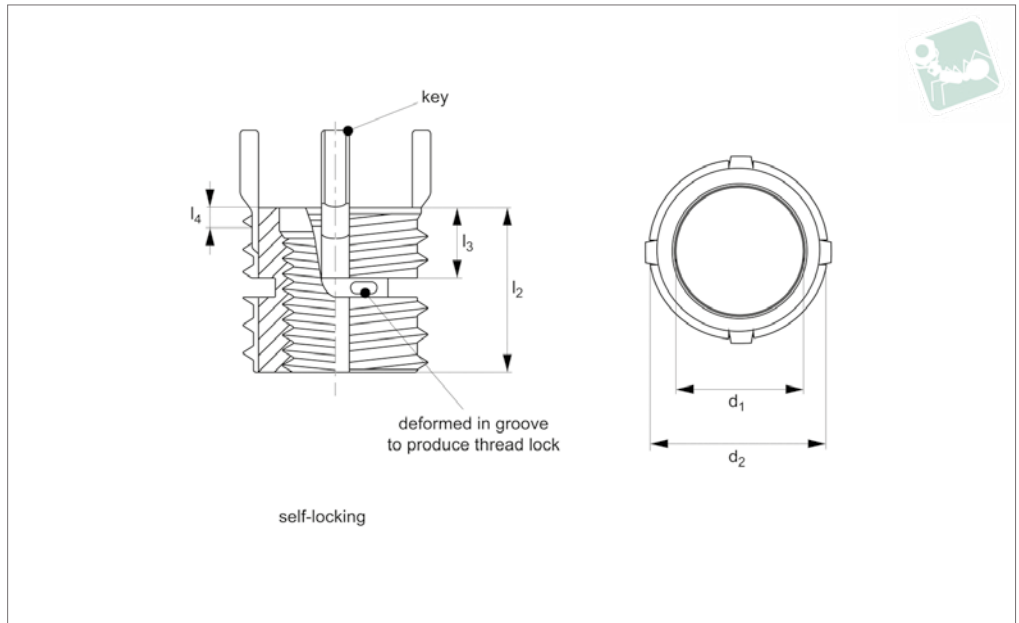

### Material

Inserts - 303 CRES.

Keys - 302 CRES.

Passivated. Dry film lubrication on self-locking inserts only.

### Technical Notes

All dimensions in inches.

Internal threads: to SAE AS8879.

General tolerances -

+/- 0,010 unless specified.

Tap drill hole tolerances -

0,234 to 0,500 = +0,004/-0,001

0,500 and over = +0,005/-0,001

**SL** = Self-Locking type, deliberate deformity in thread produces self-affect once installed (see technical diagram).

### Tips

Order installation tool separately, as identified by „Inst. Tool ref.“ in table.

### Important Notes

Four locking keys on internal threads 5/16

and over. Two locking keys on internal threads smaller than 5/16.

Installation (Inst.) drill size, counter sink, thread tap and thread depth as specified in table.

Removal (Rem.) drill size and drill depth as specified in table.

Perform to standards: MIL-I-45914A (MS51830 & NAS1394)

Order No.	Type	d <sub>1</sub> tol. 3B	Thread type d <sub>1</sub>	d <sub>2</sub> (mod.) class 2A	Thread type d <sub>2</sub>	l <sub>1</sub>	l <sub>3</sub> ±0.0 30	c'bore depth	c'sink hole size +0.010 - 0.000	Inst. drill size	Inst. thread tap depth min.	Inst. thread tap size class B	Inst. tool ref. TR1705	Removal drill size	Removal drill depth
TR1655.77300	SL	8-32	UNC	5/16-18	UNC	,312	,22	,04	,323	,272	,37	5/16-18	.0000	7/32	1/8
TR1655.77301	SL	10-24	UNC	3/8-16	UNC	,312	,22	,07	,385	,332	,37	3/8-16	.0010	9/32	1/8
TR1655.77501	SL	10-32	UNF	3/8-16	UNC	,312	,22	,07	,385	,332	,37	3/8-16	.0011	9/32	1/8
TR1655.77302	SL	1/4-20	UNC	7/16-14	UNC	,375	,22	,07	,447	,397	,43	7/16-14	.0020	11/32	3/16
TR1655.77502	SL	1/4-28	UNF	7/16-14	UNC	,375	,22	,07	,447	,397	,43	7/16-14	.0021	11/32	3/16
TR1655.77303	SL	5/16-18	UNC	1/2-13	UNC	,437	,22	,07	,510	,453	,50	1/2-13	.0030	13/32	3/16
TR1655.77503	SL	5/16-24	UNF	1/2-13	UNC	,437	,22	,07	,510	,453	,50	1/2-13	.0031	13/32	3/16
TR1655.77304	SL	3/8-16	UNC	9/16-12	UNC	,500	,25	,07	,572	,516	,56	9/16-12	.0040	15/32	3/16
TR1655.77504	SL	3/8-24	UNF	9/16-12	UNC	,500	,25	,07	,572	,516	,56	9/16-12	.0041	15/32	3/16
TR1655.77305	SL	7/16-14	UNC	5/8-11	UNC	,625	,28	,10	,635	,578	,68	5/8-11	.0050	17/32	3/16
TR1655.77505	SL	7/16-20	UNF	5/8-11	UNC	,625	,28	,10	,635	,578	,68	5/8-11	.0051	17/32	3/16
TR1655.77306	SL	1/2-13	UNC	11/16-11NS	UNS	,688	,28	,10	,700	,641	,75	11/16-11NS	.0060	19/32	3/16
TR1655.77506	SL	1/2-20	UNF	11/16-11NS	UNS	,688	,28	,10	,700	,641	,75	11/16-11NS	.0061	19/32	3/16
TR1655.77307	SL	9/16-12	UNC	13/16-16	UN	,812	,32	,10	,822	,766	,94	13/16-16	.0070	23/32	3/16
TR1655.77507	SL	9/16-18	UNF	13/16-16	UN	,812	,32	,10	,822	,766	,94	13/16-16	.0071	23/32	3/16
TR1655.77308	SL	5/8-11	UNC	7/8-14	UNF	,875	,33	,10	,885	,828	1,00	7/8-14	.0080	25/32	3/16
TR1655.77508	SL	5/8-18	UNF	7/8-14	UNF	,875	,33	,10	,885	,828	1,00	7/8-14	.0081	25/32	3/16
TR1655.77309	SL	3/4-10	UNC	1-1/8-12	UNF	1,250	,49	,10	1,145	1,062	1,44	1-1/8-12	.0090	31/32	5/16
TR1655.77509	SL	3/4-16	UNF	1-1/8-12	UNF	1,250	,49	,10	1,145	1,062	1,44	1-1/8-12	.0091	31/32	5/16
TR1655.77310	SL	7/8-9	UNC	1-1/4-12	UNF	1,375	,49	,10	1,270	1,187	1,56	1-1/4-12	.0100	1-3/32	5/16
TR1655.77510	SL	7/8-14	UNF	1-1/4-12	UNF	1,375	,49	,10	1,270	1,187	1,56	1-1/4-12	.0101	1-3/32	5/16
TR1655.77311	SL	1-8	UNC	1-3/8-12	UNF	1,500	,55	,10	1,395	1,312	1,68	1-3/8-12	.0110	1-7/32	5/16



# Threaded Insert MS/NAS - H Duty - 303 stainless steel - self-locking - MS/NAS grade

Threaded  
Inserts Stain-

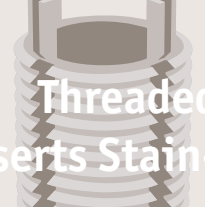

Order No.	Type	d <sub>1</sub> tol. 3B	Thread type d <sub>1</sub>	d <sub>2</sub> (mod.) class 2A	Thread type d <sub>2</sub>	l <sub>1</sub>	l <sub>3</sub> ±0.0 c'bore 30	l <sub>4</sub> depth	Inst. c'sink hole size +0.010 - 0.000	Inst. tap drill size	Inst. thread tap depth min.	Inst. thread tap size class B	Inst. tool ref. TR1705	Removal drill size	Removal drill depth
TR1655.77511	SL	1-12	UNF	1-3/8-12	UNF	1,500	,55	,10	1,395	1,312	1,68	1-3/8-12	.0111	1-7/32	5/16

THREADED INSERTS STAINLESS



TR1675

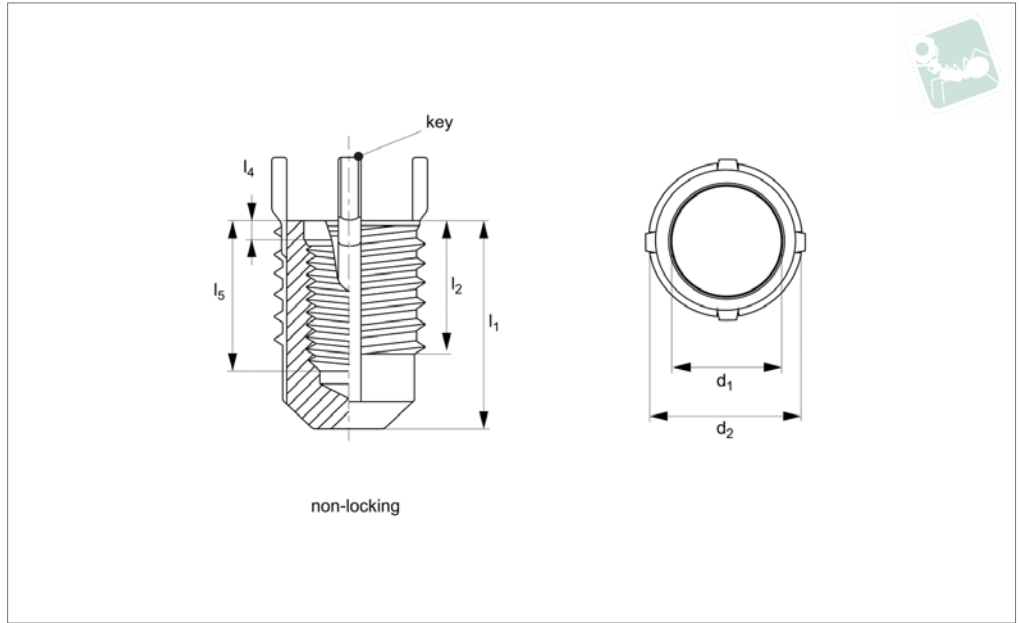

**Material**

Inserts - 303 CRES.  
Keys - 302 CRES.  
Passivated. Dry film lubrication on self-locking inserts only.

**Technical Notes**

All dimensions in inches.  
Internal threads: to SAE AS8879.  
General tolerances -  
+/- 0,010 unless specified.

**Tap drill hole tolerances -**

0,234 to 0,500 = +0,004/-0,001  
0,500 and over = +0,005/-0,001  
**NL** = Non-Locking type.

**Tips**

Order installation tool separately, as identified by „Inst. Tool ref.“ in table.

**Important Notes**

Four locking keys on internal threads 5/16

and over. Two locking keys on internal threads smaller than 5/16.

Installation (Inst.) drill size, counter sink, thread tap and thread depth as specified in table.

Removal (Rem.) drill size and drill depth as specified in table.

Perform to standards: MIL-I-45914A

Order No.	Type	d <sub>1</sub> tol. 3B	Thread type d <sub>1</sub>	d <sub>1</sub> (mod.) class 2A	Thread type d <sub>2</sub>	l <sub>1</sub>	l <sub>2</sub>	l <sub>4</sub> c'bore depth	l <sub>5</sub>	Inst. c'sink hole size +0.010 - 0.000	Inst. tap drill size	Inst. thread tap depth min.	Inst. thread tap size class 2B	Inst. tool ref. TR1705	Removal drill size	Removal drill depth
TR1675.83300	NL	8-32	UNC	5/16-18	UNC	,50	,31	,04	,31	,323	,272	,37	5/16-18	.0000	7/32	1/8
TR1675.83301	NL	10-24	UNC	3/8-16	UNC	,56	,31	,07	,31	,385	,332	,37	3/8-16	.0010	9/32	1/8
TR1675.83501	NL	10-32	UNF	3/8-16	UNC	,56	,31	,07	,31	,385	,332	,37	3/8-16	.0011	9/32	1/8
TR1675.83302	NL	1/4-20	UNC	7/16-14	UNC	,62	,37	,07	,37	,447	,397	,43	7/16-14	.0020	11/32	3/16
TR1675.83502	NL	1/4-28	UNF	7/16-14	UNC	,62	,37	,07	,37	,447	,397	,43	7/16-14	.0021	11/32	3/16
TR1675.83303	NL	5/16-18	UNC	1/2-13	UNC	,75	,43	,07	,43	,510	,453	,50	1/2-13	.0030	13/32	3/16
TR1675.83503	NL	5/16-24	UNF	1/2-13	UNC	,75	,43	,07	,43	,510	,453	,50	1/2-13	.0031	13/32	3/16
TR1675.83304	NL	3/8-16	UNC	9/16-12	UNC	,81	,50	,07	,50	,572	,516	,56	9/16-12	.0040	15/32	3/16
TR1675.83504	NL	3/8-24	UNF	9/16-12	UNC	,81	,50	,07	,50	,572	,516	,56	9/16-12	.0041	15/32	3/16
TR1675.83305	NL	7/16-14	UNC	5/8-11	UNC	1,00	,62	,10	,62	,635	,578	,68	5/8-11	.0050	17/32	3/16
TR1675.83505	NL	7/16-20	UNF	5/8-11	UNC	1,00	,62	,10	,62	,635	,578	,68	5/8-11	.0051	17/32	3/16
TR1675.83306	NL	1/2-13	UNC	11/16-11NS	UNS	1,06	,68	,10	,68	,700	,641	,75	11/16-11NS	.0060	19/32	3/16
TR1675.83506	NL	1/2-20	UNF	11/16-11NS	UNS	1,06	,68	,10	,68	,700	,641	,75	11/16-11NS	.0061	19/32	3/16
TR1675.83307	NL	9/16-12	UNC	13/16-16	UN	1,25	,81	,10	,81	,822	,766	,94	13/16-16	.0070	23/32	3/16
TR1675.83507	NL	9/16-18	UNF	13/16-16	UN	1,25	,81	,10	,81	,822	,766	,94	13/16-16	.0071	23/32	3/16
TR1675.83308	NL	5/8-11	UNC	7/8-14	UNF	1,31	,87	,10	,87	,885	,828	1,00	7/8-14	.0080	25/32	3/16
TR1675.83508	NL	5/8-18	UNF	7/8-14	UNF	1,31	,87	,10	,87	,885	,828	1,00	7/8-14	.0081	25/32	3/16
TR1675.83509	NL	3/4-16	UNF	1-1/8-12	UNF	1,75	1,25	,10	1,25	1,145	1,062	1,44	1-1/8-12	.0091	31/32	5/16
TR1675.83310	NL	7/8-9	UNF	1-1/4-12	UNF	1,94	1,37	,10	1,37	1,270	1,187	1,56	1-1/4-12	.0100	1-3/32	5/16
TR1675.83510	NL	7/8-14	UNC	1-1/4-12	UNF	1,94	1,37	,10	1,37	1,270	1,187	1,56	1-1/4-12	.0101	1-3/32	5/16
TR1675.83311	NL	1-8	UNF	1-3/8-12	UNF	2,12	1,50	,10	1,50	1,395	1,312	1,68	1-3/8-12	.0110	1-7/32	5/16
TR1675.83511	NL	1-12	UNC	1-3/8-12	UNF	2,12	1,50	,10	1,50	1,395	1,312	1,68	1-3/8-12	.0111	1-7/32	5/16





# Blind Threaded Insert - H Duty - Inch

303 stainless steel - self-locking

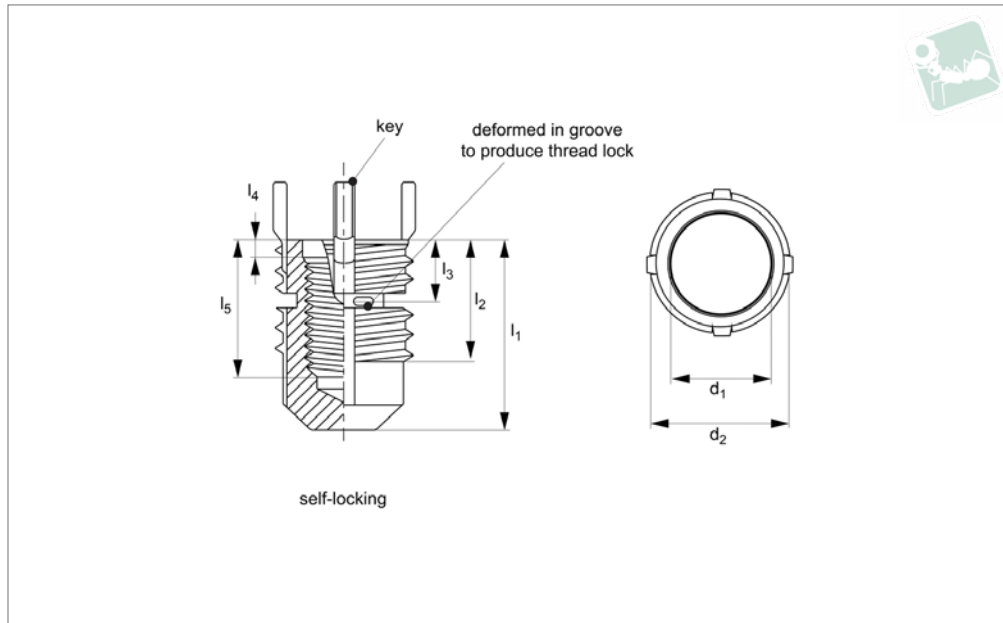
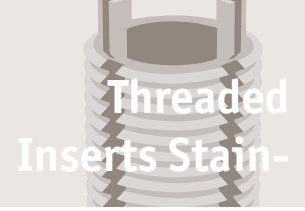

**TR1676**

THREADED INSERTS STAINLESS

### Material

Inserts - 303 CRES.  
 Keys - 302 CRES.  
 Passivated. Dry film lubrication on self-locking inserts only.

### Technical Notes

All dimensions in inches.  
 Internal threads: to SAE AS8879.  
 General tolerances -  
 +/- 0,010 unless specified.

### Tap drill hole tolerances -

0,234 to 0,500 = +0,004/-0,001  
 0,500 and over = +0,005/-0,001  
**SL** = Self-Locking type, deliberate deformity in thread produces self-affect once installed (see technical diagram).

### Tips

Order installation tool separately, as identified by „Inst. Tool ref.“ in table.

### Important Notes

Four locking keys on internal threads 5/16 and over. Two locking keys on internal threads smaller than 5/16.  
 Installation (Inst.) drill size, counter sink, thread tap and thread depth as specified in table.  
 Removal (Rem.) drill size and drill depth as specified in table.  
 Perform to standards: MIL-I-45914A

Order No.	Type	d <sub>1</sub> tol. 3B	Thread type d <sub>1</sub>	d <sub>2</sub> (mod.) class 2A	Thread type d <sub>2</sub>	l <sub>1</sub>	l <sub>2</sub>	l <sub>3</sub> ±0,030
TR1676.84300	SL	8-32	UNC	5/16-18	UNC	,50	,31	,22
TR1676.84301	SL	10-24	UNC	3/8-16	UNC	,56	,31	,22
TR1676.84501	SL	10-32	UNF	3/8-16	UNC	,56	,31	,22
TR1676.84302	SL	1/4-20	UNC	7/16-14	UNC	,62	,37	,22
TR1676.84502	SL	1/4-28	UNF	7/16-14	UNC	,62	,37	,22
TR1676.84303	SL	5/16-18	UNC	1/2-13	UNC	,75	,43	,22
TR1676.84503	SL	5/16-24	UNF	1/2-13	UNC	,75	,43	,22
TR1676.84304	SL	3/8-16	UNC	9/16-12	UNC	,81	,50	,25
TR1676.84504	SL	3/8-24	UNF	9/16-12	UNC	,81	,50	,25
TR1676.84305	SL	7/16-14	UNC	5/8-11	UNC	1.00	,62	,28
TR1676.84505	SL	7/16-20	UNF	5/8-11	UNC	1.00	,62	,28
TR1676.84306	SL	1/2-13	UNC	11/16-11NS	UNS	1.06	,68	,28
TR1676.84506	SL	1/2-20	UNF	11/16-11NS	UNS	1.06	,68	,28
TR1676.84307	SL	9/16-12	UNC	13/16-16	UN	1.25	,81	,32
TR1676.84507	SL	9/16-18	UNF	13/16-16	UN	1.25	,81	,32
TR1676.84308	SL	5/8-11	UNC	7/8-14	UNF	1.31	,87	,33
TR1676.84508	SL	5/8-18	UNF	7/8-14	UNF	1.31	,87	,33
TR1676.84309	SL	3/4-10	UNF	1-1/8-12	UNF	1.75	1.25	,49
TR1676.84509	SL	3/4-16	UNF	1-1/8-12	UNF	1.75	1.25	,49
TR1676.84310	SL	7/8-9	UNC	1-1/4-12	UNF	1.94	1.37	,49
TR1676.84510	SL	7/8-14	UNF	1-1/4-12	UNF	1.94	1.37	,49
TR1676.84311	SL	1-8	UNC	1-3/8-12	UNF	2.12	1.50	,55
TR1676.84511	SL	1-12	UNF	1-3/8-12	UNF	2.12	1.50	,55



Order No.	l <sub>4</sub> c'bore depth	l <sub>5</sub>	Inst. c'sink hole size +0.010 -0.000	Inst. tap drill size	Inst. thread tap depth min.	Inst. thread tap size class 2B	Inst. tool ref. TR1705	Removal drill size	Removal drill depth
TR1676.84300	,04	,31	,323	,272	,37	5/16-18	.0000	7/32	3/16
TR1676.84301	,07	,31	,385	,332	,37	3/8-16	.0010	9/32	3/16
TR1676.84501	,07	,31	,385	,332	,37	3/8-16	.0011	9/32	3/16
TR1676.84302	,07	,37	,447	,397	,43	7/16-14	.0020	11/32	3/16
TR1676.84502	,07	,37	,447	,397	,43	7/16-14	.0021	11/32	3/16
TR1676.84303	,07	,43	,510	,453	,50	1/2-13	.0030	13/32	3/16
TR1676.84503	,07	,43	,510	,453	,50	1/2-13	.0031	13/32	3/16
TR1676.84304	,07	,50	,572	,516	,56	9/16-12	.0040	15/32	3/16
TR1676.84504	,07	,50	,572	,516	,56	9/16-12	.0041	15/32	3/16
TR1676.84305	,10	,62	,635	,578	,68	5/8-11	.0050	17/32	3/16
TR1676.84505	,10	,62	,635	,578	,68	5/8-11	.0051	17/32	3/16
TR1676.84306	,10	,68	,700	,641	,75	11/16-11NS	.0060	19/32	3/16
TR1676.84506	,10	,68	,700	,641	,75	11/16-11NS	.0061	19/32	3/16
TR1676.84307	,10	,81	,822	,766	,94	13/16-16	.0070	23/32	3/16
TR1676.84507	,10	,81	,822	,766	,94	13/16-16	.0071	23/32	3/16
TR1676.84308	,10	,87	,885	,828	1.00	7/8-14	.0080	25/32	3/16
TR1676.84508	,10	,87	,885	,828	1.00	7/8-14	.0081	25/32	3/16
TR1676.84309	,10	1.25	1.145	1.062	1.44	1-1/8-12	.0090	31/32	5/16
TR1676.84509	,10	1.25	1.145	1.062	1.44	1-1/8-12	.0091	31/32	5/16
TR1676.84310	,10	1.37	1.270	1.187	1.56	1-1/4-12	.0100	1-3/32	5/16
TR1676.84510	,10	1.37	1.270	1.187	1.56	1-1/4-12	.0101	1-3/32	5/16
TR1676.84311	,10	1.50	1.395	1.312	1.68	1-3/8-12	.0110	1-7/32	5/16
TR1676.84511	,10	1.50	1.395	1.312	1.68	1-3/8-12	.0111	1-7/32	5/16



# Threaded Insert MS/NAS - Extra H

303 stainless steel - non-locking - MS/NAS grade

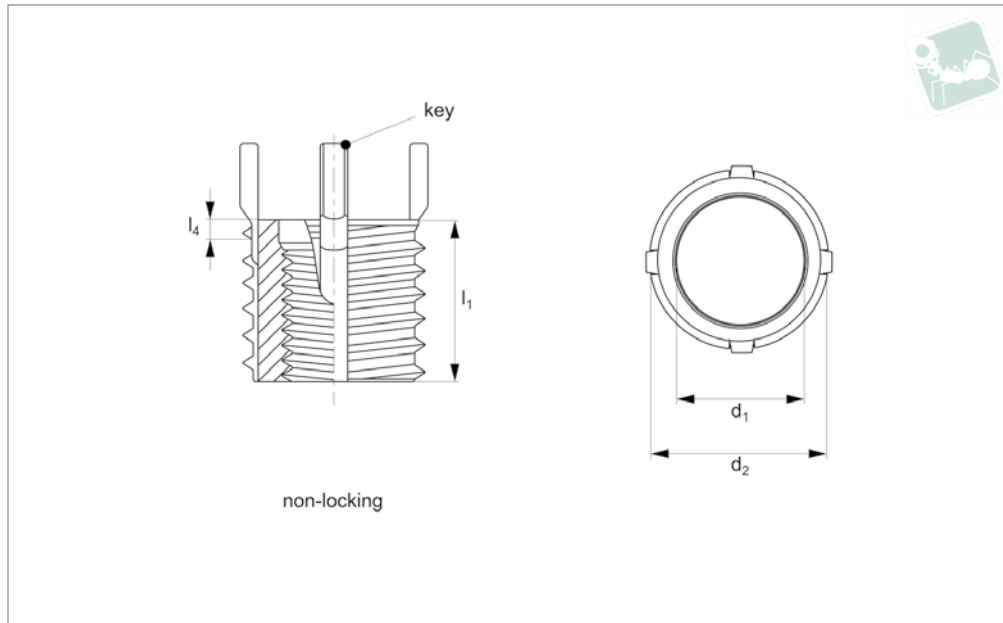
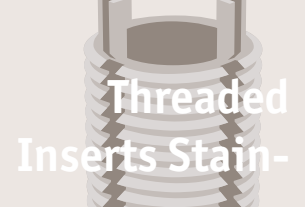

**TR1656**

THREADED INSERTS STAINLESS

### Material

Inserts - 303 CRES.  
Keys - 302 CRES.  
Passivated. Dry film lubrication on self-locking inserts only.

### Technical Notes

All dimensions in inches.  
Internal threads: to SAE AS8879.  
General tolerances -  
+/- 0,010 unless specified.

Tap drill hole tolerances -  
0,234 to 0,500 = +0,004/-0,001  
0,500 and over = +0,005/-0,001  
**NL** = Non-Locking type.

### Tips

Order installation tool separately, as identified by „Inst. Tool ref.“ in table.

### Important Notes

Four locking keys on internal threads 1/4

and over. Two locking keys on internal threads smaller than 1/4.  
Installation (Inst.) drill size, counter sink, thread tap and thread depth as specified in table.  
Removal (Rem.) drill size and drill depth as specified in table.  
Perform to standards: MIL-I-45914A (MS51832)

Order No.	Type	d <sub>1</sub> tol. 3B	Thread type d <sub>1</sub>	d <sub>2</sub> (mod.) class 2A	Thread type d <sub>2</sub>	l <sub>1</sub>	l <sub>4</sub> c'bore depth	Inst. c'sink hole size +0.010 - 0.000	Inst. tap drill size	Inst. thread tap depth min.	Inst. thread tap size class 2B	Inst. tool ref. TR1706	Removal drill size	Removal drill depth
TR1656.76333	NL	10-24	UNC	7/16-14	UNC	,312	,07	,447	,397	,37	7/16-14	.0330	11/32	3/16
TR1656.76533	NL	10-32	UNF	7/16-14	UNC	,312	,07	,447	,397	,37	7/16-14	.0331	11/32	3/16
TR1656.76334	NL	1/4-20	UNC	1/2-13	UNC	,375	,07	,510	,453	,44	1/2-13	.0340	13/32	3/16
TR1656.76534	NL	1/4-28	UNF	1/2-13	UNC	,375	,07	,510	,453	,44	1/2-13	.0341	13/32	3/16
TR1656.76335	NL	5/16-18	UNC	9/16-12	UNC	,437	,07	,572	,516	,50	9/16-12	.0350	15/32	3/16
TR1656.76535	NL	5/16-24	UNF	9/16-12	UNC	,437	,07	,572	,516	,50	9/16-12	.0351	15/32	3/16
TR1656.76336	NL	3/8-16	UNC	5/8-11	UNC	,500	,07	,635	,578	,56	5/8-11	.0360	17/32	3/16
TR1656.76536	NL	3/8-24	UNF	5/8-11	UNC	,500	,07	,635	,578	,56	5/8-11	.0361	17/32	3/16
TR1656.76337	NL	7/16-14	UNC	11/16-11NS	UNS	,625	,10	,700	,641	,68	11/16-11NS	.0370	19/32	3/16
TR1656.76537	NL	7/16-20	UNF	11/16-11NS	UNS	,625	,10	,700	,641	,68	11/16-11NS	.0371	19/32	3/16
TR1656.76338	NL	1/2-13	UNC	13/16-16	UNF	,688	,10	,822	,766	,75	13/16-16	.0380	23/32	3/16
TR1656.76538	NL	1/2-20	UNF	13/16-16	UNF	,688	,10	,822	,766	,75	13/16-16	.0381	23/32	3/16
TR1656.76339	NL	9/16-12	UNC	7/8-14	UNF	,812	,10	,885	,828	,94	7/8-14	.0390	25/32	3/16
TR1656.76539	NL	9/16-18	UNF	7/8-14	UNF	,812	,10	,885	,828	,94	7/8-14	.0391	25/32	3/16
TR1656.76340	NL	5/8-11	UNC	1-12	UNF	,875	,10	1,020	,937	1,00	1-12	.0400	27/32	5/16
TR1656.76540	NL	5/8-18	UNF	1-12	UNF	,875	,10	1,020	,937	1,00	1-12	.0401	27/32	5/16
TR1656.76341	NL	3/4-10	UNC	1-1/4-12	UNF	1,125	,10	1,270	1,187	1,31	1-1/4-12	.0410	1-3/32	5/16
TR1656.76541	NL	3/4-16	UNF	1-1/4-12	UNF	1,125	,10	1,270	1,187	1,31	1-1/4-12	.0411	1-3/32	5/16
TR1656.76342	NL	7/8-9	UNC	1-3/8-12	UNF	1,250	,10	1,395	1,312	1,44	1-3/8-12	.0420	1-7/32	5/16
TR1656.76542	NL	7/8-14	UNF	1-3/8-12	UNF	1,250	,10	1,395	1,312	1,44	1-3/8-12	.0421	1-7/32	5/16
TR1656.76343	NL	1-8	UNC	1-1/2-12	UNF	1,375	,10	1,520	1,437	1,56	1-1/2-12	.0430	1-11/32	5/16
TR1656.76543	NL	1-12	UNF	1-1/2-12	UNF	1,375	,10	1,520	1,437	1,56	1-1/2-12	.0431	1-11/32	5/16



TR1566

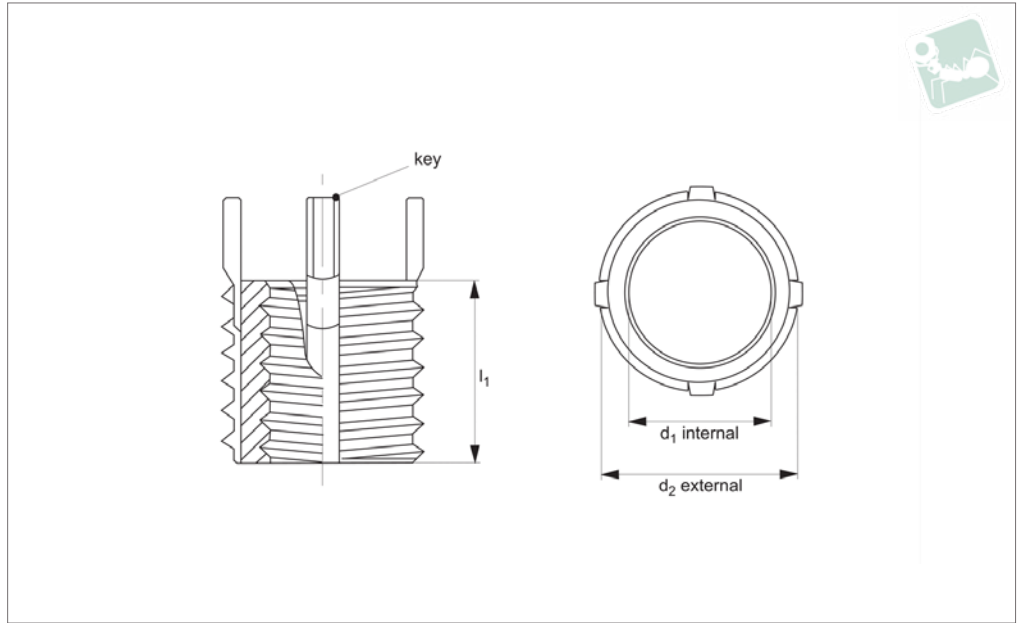

**Material**

Inserts: stainless steel (AISI 303) or equivalent. Passivated.

Keys: stainless steel (302 CRES) or equivalent. Passivated.

**Technical Notes**

**General tolerances:**

± 0,010" unless specified.

**Tap drill hole tolerances:**

0,234 to 0,500 = +0,004/-0,001"  
0,500 and over = +0,005/-0,001"

**Tips**

Order installation tool separately, as identified by „Inst. tool ref.“ in table.

**Important Notes**

Four locking keys on internal threads 5/16" and over. Two locking keys on internal

threads smaller than 5/16".

Installation (Inst.) drill size, countersink, thread tap and thread depth as specified in table.

Removal drill size and drill depth as specified in table.

**All dimensions in inches.**

Order No.	Int. d <sub>1</sub> tol. 2B	Int. thread type d <sub>1</sub>	Ext. d <sub>2</sub> (mod.) class 2A	Ext. thread type d <sub>2</sub>	l <sub>1</sub>	Inst. c'sink dia. +0.010 - 0.000	Inst. tap drill size	Inst. thread depth min.	Inst. thread tap tol. 2B	Inst. tool ref. 22058	Removal drill size	Removal drill depth
TR1566.66331	6 - 32	UNC	5/16" - 18	UNC	0,31	0,32	17/64"	0,37	5/16"-18	.W0310	7/32"	1/8"
TR1566.66332	8 - 32	UNC	3/8" - 16	UNC	0,31	0,38	21/64"	0,37	3/8"-16	.W0320	9/32"	1/8"
TR1566.66333	10 - 24	UNC	7/16" - 14	UNC	0,31	0,44	25/64"	0,37	7/16"-14	.W0330	11/32"	3/16"
TR1566.66533	10 - 32	UNF	7/16" - 14	UNC	0,31	0,44	25/64"	0,37	7/16"-14	.W0330	11/32"	3/16"
TR1566.66334	1/4" - 20	UNC	1/2" - 13	UNC	0,37	0,51	29/64"	0,43	1/2"-13	.W0340	13/32"	3/16"
TR1566.66534	1/4" - 28	UNF	1/2" - 13	UNC	0,37	0,51	29/64"	0,43	1/2"-13	.W0340	13/32"	3/16"
TR1566.66335	5/16" -	UNC	9/16" - 12	UNC	0,43	0,57	33/64"	0,50	9/16"-12	.W0350	15/32"	3/16"
TR1566.66535	5/16" -	UNF	9/16" - 12	UNC	0,43	0,57	33/64"	0,50	9/16"-12	.W0350	15/32"	3/16"
TR1566.66336	3/8" - 16	UNC	5/8" - 11	UNC	0,50	0,63	37/64"	0,56	5/8"-11	.W0360	17/32"	3/16"
TR1566.66536	3/8" - 24	UNF	5/8" - 11	UNC	0,50	0,63	37/64"	0,56	5/8"-11	.W0360	17/32"	3/16"
TR1566.66337	7/16" -	UNC	3/4" - 16	UNF	0,62	0,76	45/64"	0,68	3/4"-16	.W0370	21/32"	3/16"
TR1566.66537	7/16" -	UNF	3/4" - 16	UNF	0,62	0,76	45/64"	0,68	3/4"-16	.W0370	21/32"	3/16"
TR1566.66338	1/2" - 13	UNC	7/8" - 14	UNF	0,68	0,88	53/64"	0,75	7/8"-14	.W0380	25/32"	5/16"
TR1566.66538	1/2" - 20	UNF	7/8" - 14	UNF	0,68	0,88	53/64"	0,75	7/8"-14	.W0380	25/32"	5/16"
TR1566.66339	9/16" -	UNC	7/8" - 14	UNF	0,81	0,88	53/64"	0,94	7/8"-14	.W0390	25/32"	5/16"
TR1566.66539	9/16" -	UNF	7/8" - 14	UNF	0,81	0,88	53/64"	0,94	7/8"-14	.W0390	25/32"	5/16"
TR1566.66340	5/8" - 11	UNC	1" - 12	UNF	0,87	1,02	15/16"	1,00	1"-12	.W0400	27/32"	5/16"
TR1566.66540	5/8" - 18	UNF	1" - 12	UNF	0,87	1,02	15/16"	1,00	1"-12	.W0400	27/32"	5/16"
TR1566.66341	3/4" - 10	UNC	1 - 1/4" - 12	UNF	1,12	1,27	1-3/16"	1,31	1-1/4"-12	.W0410	1-3/32"	5/16"
TR1566.66541	3/4" - 16	UNF	1 - 1/4" - 12	UNF	1,12	1,27	1-3/16"	1,31	1-1/4"-12	.W0410	1-3/32"	5/16"
TR1566.66342	7/8" - 9	UNC	1 - 3/8" - 12	UNF	1,25	1,39	1-5/16"	1,44	1-3/8"-12	.W0420	1-7/32"	5/16"
TR1566.66542	7/8" - 14	UNF	1 - 3/8" - 12	UNF	1,25	1,39	1-5/16"	1,44	1-3/8"-12	.W0420	1-7/32"	5/16"
TR1566.66343	1" - 8	UNC	1 - 1/2" - 12	UNF	1,37	1,52	1-7/16"	1,56	1-1/2"-12	.W0430	1-11/32"	5/16"
TR1566.66543	1" - 12	UNF	1 - 1/2" - 12	UNF	1,37	1,52	1-7/16"	1,56	1-1/2"-12	.W0430	1-11/32"	5/16"



# Threaded Insert MS/NAS - Extra H

303 stainless steel - self-locking - MS/NAS grade

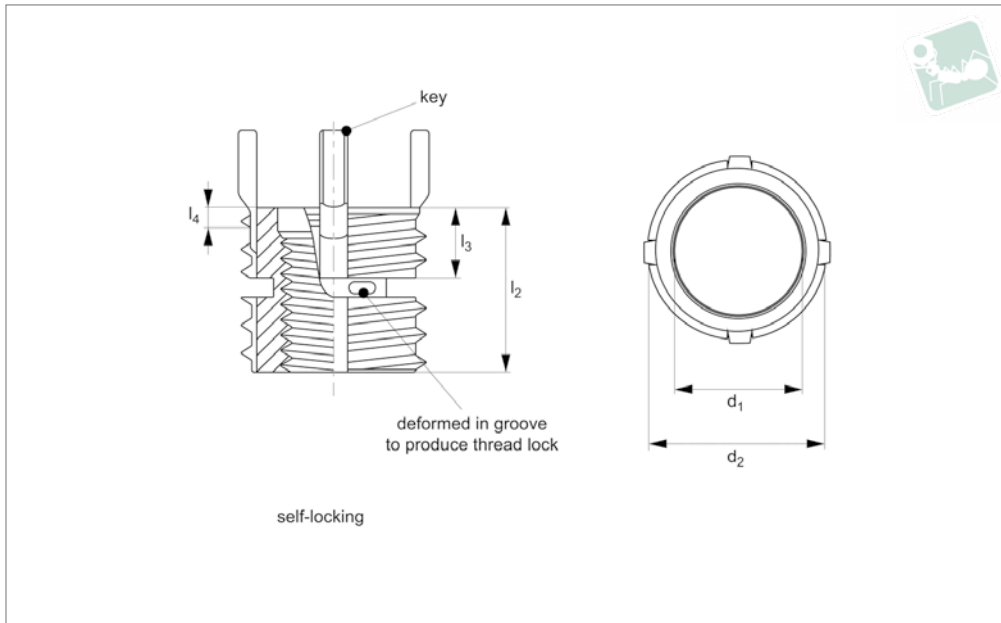
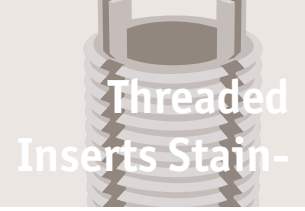

## TR1657

THREADED INSERTS STAINLESS

### Material

Inserts - 303 CRES.  
Keys - 302 CRES.  
Passivated. Dry film lubrication on self-locking inserts only.

### Technical Notes

All dimensions in inches.  
Internal threads: to SAE AS8879.  
General tolerances -  
+/- 0,010 unless specified.  
Tap drill hole tolerances -

0,234 to 0,500 = +0,004/-0,001  
0,500 and over = +0,005/-0,001  
**SL** = Self-Locking type, deliberate deformity in thread produces self-affect once installed (see technical diagram).

### Tips

Order installation tool separately, as identified by „Inst. Tool ref.“ in table.

### Important Notes

Four locking keys on internal threads 1/4

and over. Two locking keys on internal threads smaller than 1/4.  
Installation (Inst.) drill size, counter sink, thread tap and thread depth as specified in table.  
Removal (Rem.) drill size and drill depth as specified in table.  
Perform to standards: MIL-I-45914A (MS51832)

Order No.	Type	d <sub>1</sub> tol. 3B	Thread type d <sub>1</sub>	d <sub>2</sub> (mod.) class 2A	Thread type d <sub>2</sub>	l <sub>1</sub>	l <sub>3</sub> ±0.030
TR1657.77333	SL	10-24	UNC	7/16-14	UNC	,312	,22
TR1657.77533	SL	10-32	UNF	7/16-14	UNC	,312	,22
TR1657.77334	SL	1/4-20	UNC	1/2-13	UNC	,375	,22
TR1657.77534	SL	1/4-28	UNF	1/2-13	UNC	,375	,22
TR1657.77335	SL	5/16-18	UNC	9/16-12	UNC	,437	,22
TR1657.77535	SL	5/16-24	UNF	9/16-12	UNC	,437	,22
TR1657.77336	SL	3/8-16	UNC	5/8-11	UNC	,500	,25
TR1657.77536	SL	3/8-24	UNF	5/8-11	UNC	,500	,25
TR1657.77337	SL	7/16-14	UNC	11/16-11NS	UNS	,625	,28
TR1657.77537	SL	7/16-20	UNF	11/16-11NS	UNS	,625	,28
TR1657.77338	SL	1/2-13	UNC	13/16-16	UNF	,688	,28
TR1657.77538	SL	1/2-20	UNF	13/16-16	UNF	,688	,28
TR1657.77339	SL	9/16-12	UNC	7/8-14	UNF	,812	,32
TR1657.77539	SL	9/16-18	UNF	7/8-14	UNF	,812	,32
TR1657.77340	SL	5/8-11	UNC	1-12	UNF	,875	,33
TR1657.77540	SL	5/8-18	UNF	1-12	UNF	,875	,33
TR1657.77341	SL	3/4-10	UNC	1-1/4-12	UNF	1.250	,49
TR1657.77541	SL	3/4-16	UNF	1-1/4-12	UNF	1.250	,49
TR1657.77342	SL	7/8-9	UNC	1-3/8-12	UNF	1.375	,49
TR1657.77542	SL	7/8-14	UNF	1-3/8-12	UNF	1.375	,49
TR1657.77343	SL	1-8	UNC	1-1/2-12	UNF	1.500	,55
TR1657.77543	SL	1-12	UNF	1-1/2-12	UNF	1.500	,55



Order No.	1/4 c'bore depth	Inst. c'sink hole size +0.010 -0.000	Inst. tap drill size	Inst. thread tap depth min.	Inst. thread tap size class 2B	Inst. tool ref. TR1706	Removal drill size	Removal drill depth
TR1657.77333	,07	,447	,397	,37	7/16-14	.0330	11/32	3/16
TR1657.77533	,07	,447	,397	,37	7/16-14	.0331	11/32	3/16
TR1657.77334	,07	,510	,453	,44	1/2-13	.0340	13/32	3/16
TR1657.77534	,07	,510	,453	,44	1/2-13	.0341	13/32	3/16
TR1657.77335	,07	,572	,516	,50	9/16-12	.0350	15/32	3/16
TR1657.77535	,07	,572	,516	,50	9/16-12	.0351	15/32	3/16
TR1657.77336	,07	,635	,578	,56	5/8-11	.0360	17/32	3/16
TR1657.77536	,07	,635	,578	,56	5/8-11	.0361	17/32	3/16
TR1657.77337	,10	,700	,641	,68	11/16-11NS	.0370	19/32	3/16
TR1657.77537	,10	,700	,641	,68	11/16-11NS	.0371	19/32	3/16
TR1657.77338	,10	,822	,766	,75	13/16-16	.0380	23/32	3/16
TR1657.77538	,10	,822	,766	,75	13/16-16	.0381	23/32	3/16
TR1657.77339	,10	,885	,828	,94	7/8-14	.0390	25/32	3/16
TR1657.77539	,10	,885	,828	,94	7/8-14	.0391	25/32	3/16
TR1657.77340	,10	1.020	,937	1.00	1-12	.0400	27/32	5/16
TR1657.77540	,10	1.020	,937	1.00	1-12	.0401	27/32	5/16
TR1657.77341	,10	1.270	1.187	1.44	1-1/4-12	.0410	1-3/32	5/16
TR1657.77541	,10	1.270	1.187	1.44	1-1/4-12	.0411	1-3/32	5/16
TR1657.77342	,10	1.395	1.312	1.56	1-3/8-12	.0420	1-7/32	5/16
TR1657.77542	,10	1.395	1.312	1.56	1-3/8-12	.0421	1-7/32	5/16
TR1657.77343	,10	1.520	1.437	1.68	1-1/2-12	.0430	1-11/32	5/16
TR1657.77543	,10	1.520	1.437	1.68	1-1/2-12	.0431	1-11/32	5/16



# Floating Threaded Insert - Mini - Inch

303 stainless steel - non-locking

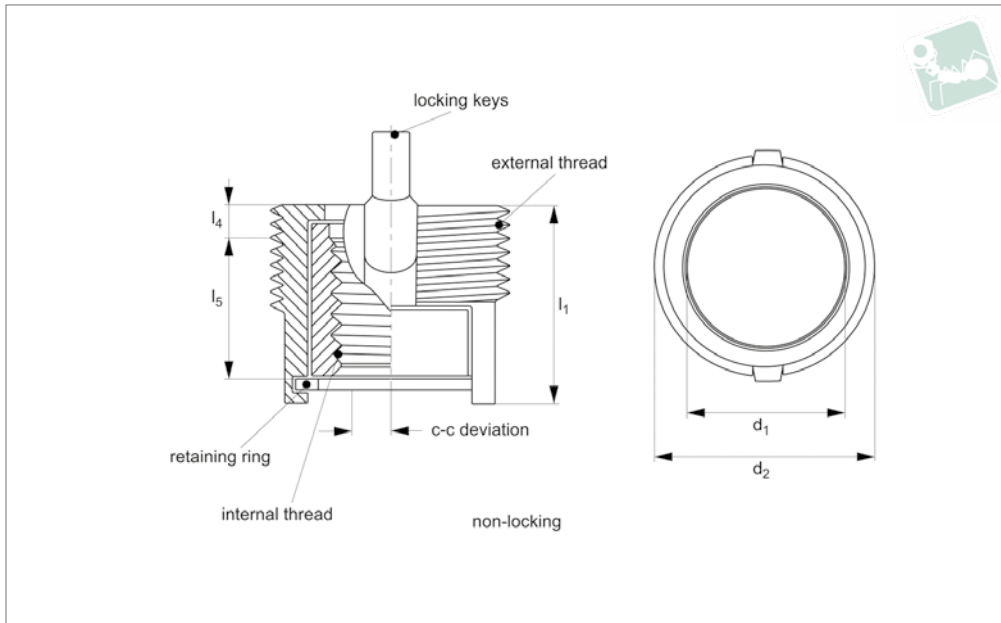
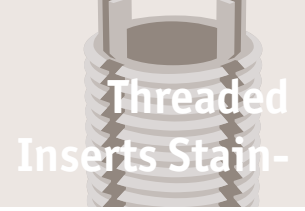

**TR1680**

THREADED INSERTS STAINLESS

**Material**

Inserts - 303 CRES.  
 Keys and retaining ring - 302 CRES.  
 Passivated. Dry film lubrication on self-locking inserts only.

**Technical Notes**

All dimensions in inches.  
 Internal threads: to SAE AS8879.  
 General tolerances -

+/- 0,010 unless specified.  
 Tap drill hole tolerances -  
 0,130 to 0,233 = +0,003/-0,001  
**NL** = Non-thread locking type.

**Tips**

Order installation tool separately, as identified by „Inst. Tool ref.“ in table.

**Important Notes**

Four locking keys on internal threads 5/16 and over. Two locking keys on internal threads smaller than 5/16.  
 Installation (Inst.) drill size, counter sink, thread tap and thread depth as specified in table.  
 Removal (Rem.) drill size and drill depth as specified in table.

Order No.	Type	d <sub>1</sub> tol. 3B	Thread type d <sub>1</sub>	l <sub>1</sub> ±0.01 5	d <sub>2</sub> tol. 2A	Thread type d <sub>2</sub>	l <sub>4</sub>	l <sub>5</sub>	c-c float min.	Inst. c'sink dia. +0.01 0 - 0.000	Inst. tap drill size	Inst. thread tap depth min.	Inst. thread tap size class 2B	Inst. tool ref. TR1720	Removal drill size	Removal drill depth
<b>TR1680.87283</b>	NL	2-56	UNC	,19	1/4-28	UNF	,05	,10	,015	,250	,228	,12	1/4-28	.0830	#8	3/32
<b>TR1680.87284</b>	NL	4-40	UNC	,32	5/16-24	UNF	,07	,21	,020	,323	,272	,31	5/16-24	.0840	7/32	1/8
<b>TR1680.87285</b>	NL	6-32	UNC	,36	3/8-24	UNF	,08	,22	,030	,385	,332	,38	3/8-24	.0850	9/32	1/8
<b>TR1680.87286</b>	NL	8-32	UNC	,36	3/8-24	UNF	,08	,22	,030	,385	,332	,38	3/8-24	.0860	9/32	1/8



**TR1681**

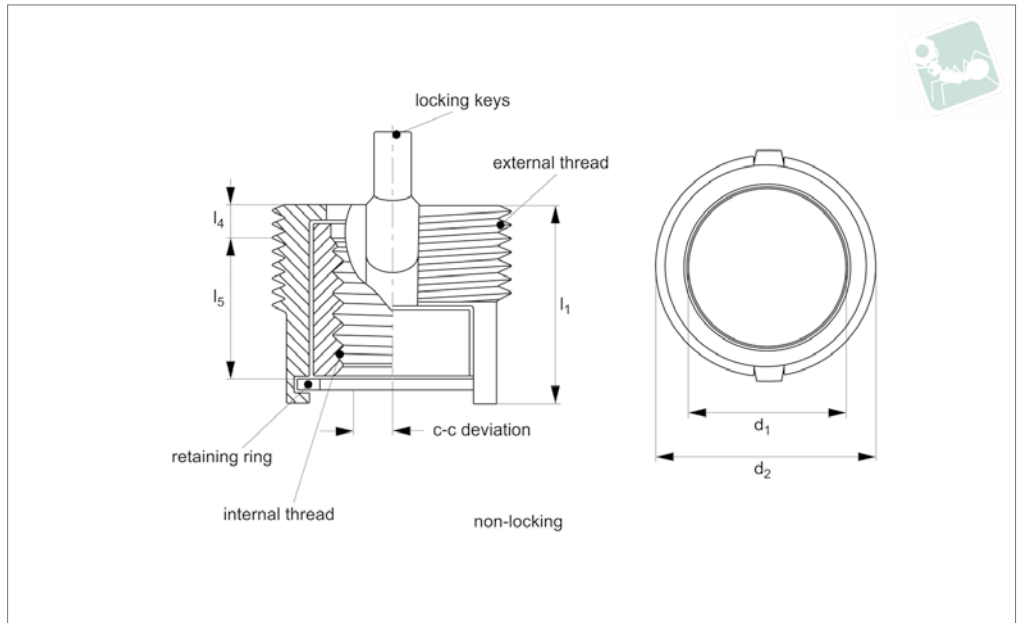

**Material**

Inserts - 303 CRES.  
 Keys and retaining ring - 302 CRES.  
 Passivated. Dry film lubrication on self-locking inserts only.

**Technical Notes**

All dimensions in inches.  
 Internal threads: to SAE AS8879.  
 General tolerances -  
 +/- 0,010 unless specified.

Tap drill hole tolerances -

0,130 to 0,233 = +0,003/-0,001  
**SL** = Self-Locking type, deliberate deformity in thread produces self-affect once installed (see technical diagram).

**Tips**

Order installation tool separately, as identified by „Inst. Tool ref.“ in table.

**Important Notes**

Four locking keys on internal threads 5/16 and over. Two locking keys on internal threads smaller than 5/16.  
 Installation (Inst.) drill size, counter sink, thread tap and thread depth as specified in table.  
 Removal (Rem.) drill size and drill depth as specified in table.  
 Perform to standards

Order No.	Type	d <sub>1</sub> tol.	Thread 3B type	d <sub>1</sub> ±0,01 5	d <sub>2</sub> tol. 2A	Thread type	d <sub>2</sub>	l <sub>4</sub>	l <sub>5</sub>	c-c float min.	Inst. c'sink dia. +0,01 0 -0,000	Inst. tap drill size	Inst. thread tap depth min.	Inst. thread tap size class 2B	Inst. tool ref. TR1720	Removal drill size	Removal drill depth
<b>TR1681.87583</b>	SL	2-56	UNC	,19	1/4-28	UNF	,05	,10	,015	,250	,228	,12	1/4-28	.0830	#8	3/32	
<b>TR1681.87584</b>	SL	4-40	UNC	,32	5/16-24	UNF	,07	,21	,020	,323	,272	,31	5/16-24	.0840	7/32	1/8	
<b>TR1681.87585</b>	SL	6-32	UNC	,36	3/8-24	UNF	,08	,22	,030	,385	,332	,38	3/8-24	.0850	9/32	1/8	
<b>TR1681.87586</b>	SL	8-32	UNC	,36	3/8-24	UNF	,08	,22	,030	,385	,332	,38	3/8-24	.0860	9/32	1/8	





# Floating Threaded Insert - H Duty - 4140 steel - non-locking

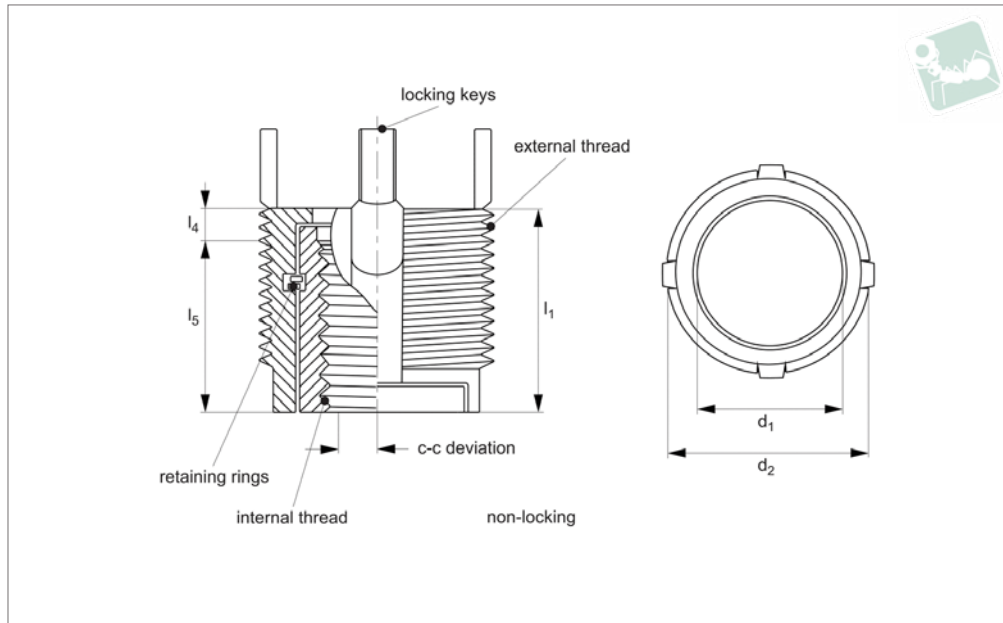
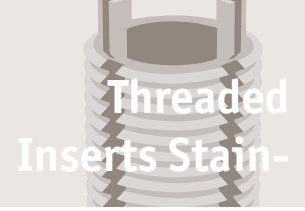

## TR1685

THREADED INSERTS STAINLESS

### Material

Inserts - 4140 alloy steel (160 KSI Min).  
Keys - 302 CRES.  
Cadmium plate (QQ-P-416 Type II, Cl. 2).  
Dry film lubrication on self-locking inserts only.

### Technical Notes

All dimensions in inches.  
Internal threads: to SAE AS8879.  
General tolerances -

+/- 0,010 unless specified.  
Tap drill hole tolerances -  
0,130 to 0,233 = +0,003/-0,001  
NL = Non-thread locking type.

### Tips

Order installation tool separately, as identified by „Inst. Tool ref.“ in table.

### Important Notes

Four locking keys on internal threads 5/16

and over. Two locking keys on internal threads smaller than 5/16.  
Installation (Inst.) drill size, counter sink, thread tap and thread depth as specified in table.  
Removal (Rem.) drill size and drill depth as specified in table.  
Perform to standards:

Order No.	Type	d <sub>1</sub> tol. 3B	Thread type d <sub>1</sub> ±0.0 15	l <sub>1</sub>	d <sub>2</sub> (mod.) class 2A	Thread type d <sub>2</sub>	l <sub>4</sub>	l <sub>5</sub>	c-c float min.	Inst. c'sink dia. +0.010 - 0.000	Inst. tap drill size	Inst. thread tap depth min.	Inst. thread tap size class 2B	Inst. tool ref. TR1725	Removal drill size	Removal drill depth
TR1685.89301	NL	10-24	UNC	,40	7/16-20	UNC	,15	,25	,040	,447	,406	,39	7/16-20	.0010	11/32	5/32
TR1685.89401	NL	10-32	UNF	,40	7/16-20	UNC	,15	,25	,040	,447	,406	,39	7/16-20	.0010	11/32	5/32
TR1685.89302	NL	1/4-20	UNC	,40	1/2-20	UNF	,15	,25	,040	,510	,486	,39	1/2-20	.0020	13/32	5/32
TR1685.89402	NL	1/4-28	UNF	,40	1/2-20	UNF	,15	,25	,040	,510	,486	,39	1/2-20	.0020	13/32	5/32
TR1685.89303	NL	5/16-18	UNC	,53	5/8-18	UNF	,13	,39	,040	,635	,578	,50	5/8-18	.0030	17/32	3/16
TR1685.89403	NL	5/16-24	UNF	,53	5/8-18	UNF	,13	,39	,040	,635	,578	,50	5/8-18	.0030	17/32	3/16
TR1685.89304	NL	3/8-16	UNC	,65	3/4-16	UNF	,20	,45	,040	,760	,703	,62	3/4-16	.0040	21/32	3/16
TR1685.89404	NL	3/8-24	UNF	,65	3/4-16	UNF	,20	,45	,040	,760	,703	,62	3/4-16	.0040	21/32	3/16
TR1685.89305	NL	7/16-14	UNC	,67	7/8-14	UNF	,20	,45	,040	,885	,828	,62	7/8-14	.0050	25/32	3/16
TR1685.89405	NL	7/16-20	UNF	,67	7/8-14	UNF	,20	,45	,040	,885	,828	,62	7/8-14	.0050	25/32	3/16
TR1685.89306	NL	1/2-13	UNC	,73	1-12	UNF	,23	,50	,040	1,020	,937	,65	1-12	.0060	27/32	5/16
TR1685.89406	NL	1/2-20	UNF	,73	1-12	UNF	,23	,50	,040	1,020	,937	,65	1-12	.0060	27/32	5/16



**TR1686**

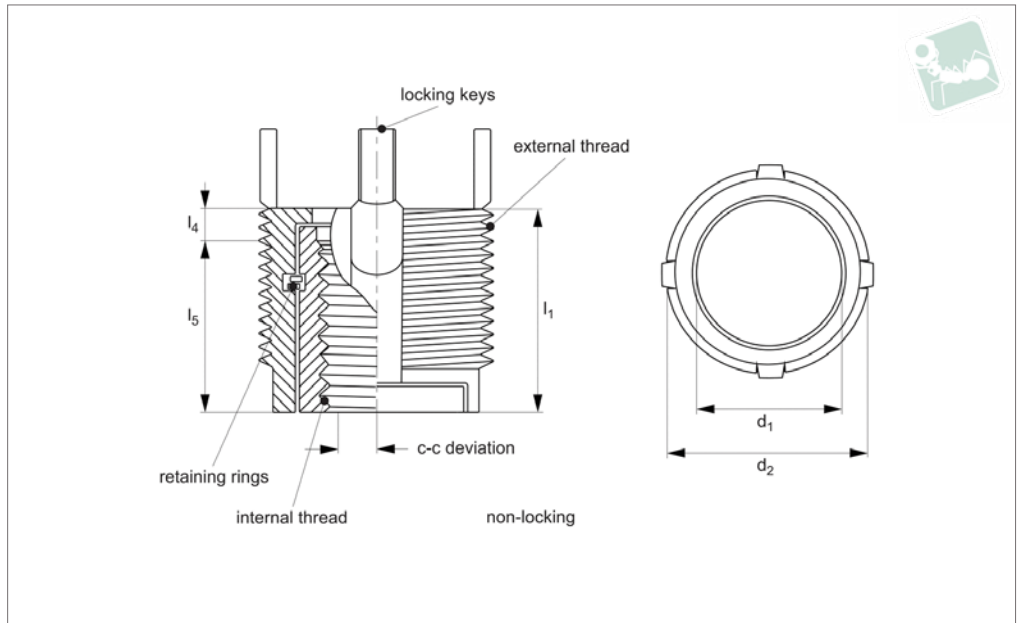

**Material**

Inserts - 4140 alloy steel (160 KSI Min).  
 Keys - 302 CRES.  
 Cadmium plate (QQ-P-416 Type II, Cl. 2).  
 Dry film lubrication on self-locking inserts only.

**Technical Notes**

All dimensions in inches.  
 Internal threads: to SAE AS8879.  
 General tolerances -

+/- 0,010 unless specified.

Tap drill hole tolerances -  
 0,130 to 0,233 = +0,003/-0,001

**SL** = Self-Locking type, deliberate deformity in thread produces self-affect once installed (see technical diagram).

**Tips**

Order installation tool separately, as identified by „Inst. Tool ref.“ in table.

**Important Notes**

Four locking keys on internal threads 5/16 and over. Two locking keys on internal threads smaller than 5/16.  
 Installation (Inst.) drill size, counter sink, thread tap and thread depth as specified in table.  
 Removal (Rem.) drill size and drill depth as specified in table.  
 Perform to standards:

Order No.	Type	d <sub>1</sub> tol. 3B	Thread type d <sub>1</sub>	l <sub>1</sub> ±0,015	d <sub>2</sub> (mod.) class 2A	Thread type d <sub>2</sub>	l <sub>4</sub>	l <sub>5</sub>	c-c float min.	Inst. c'sink dia. +0,010   -0,000	Inst. tap drill size	Inst. thread tap depth min.	Inst. thread tap size class 2B	Inst. tool ref. TR1725	Removal drill size	Removal drill depth
TR1686.89501	SL	10-24	UNC	,40	7/16-20	UNC	,15	,25	,040	,447	,406	,39	7/16-20	.0010	11/32	5/32
TR1686.89601	SL	10-32	UNF	,40	7/16-20	UNC	,15	,25	,040	,447	,406	,39	7/16-20	.0010	11/32	5/32
TR1686.89502	SL	1/4-20	UNC	,40	1/2-20	UNF	,15	,25	,040	,510	,486	,39	1/2-20	.0020	13/32	5/32
TR1686.89602	SL	1/4-28	UNF	,40	1/2-20	UNF	,15	,25	,040	,510	,486	,39	1/2-20	.0020	13/32	5/32
TR1686.89503	SL	5/16-18	UNC	,53	5/8-18	UNF	,13	,39	,040	,635	,578	,50	5/8-18	.0030	17/32	3/16
TR1686.89603	SL	5/16-24	UNF	,53	5/8-18	UNF	,13	,39	,040	,635	,578	,50	5/8-18	.0030	17/32	3/16
TR1686.89504	SL	3/8-16	UNC	,65	3/4-16	UNF	,20	,45	,040	,760	,703	,62	3/4-16	.0040	21/32	3/16
TR1686.89604	SL	3/8-24	UNF	,65	3/4-16	UNF	,20	,45	,040	,760	,703	,62	3/4-16	.0040	21/32	3/16
TR1686.89505	SL	7/16-14	UNC	,67	7/8-14	UNF	,20	,45	,040	,885	,828	,62	7/8-14	.0050	25/32	3/16
TR1686.89605	SL	7/16-20	UNF	,67	7/8-14	UNF	,20	,45	,040	,885	,828	,62	7/8-14	.0050	25/32	3/16
TR1686.89506	SL	1/2-13	UNC	,73	1-12	UNF	,23	,50	,040	1,020	,937	,65	1-12	.0060	27/32	5/16
TR1686.89606	SL	1/2-20	UNF	,73	1-12	UNF	,23	,50	,040	1,020	,937	,65	1-12	.0060	27/32	5/16



# Threaded Insert - Solid - Metric stainless steel

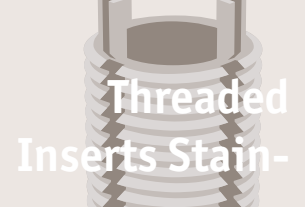

Threaded  
Inserts Stain-

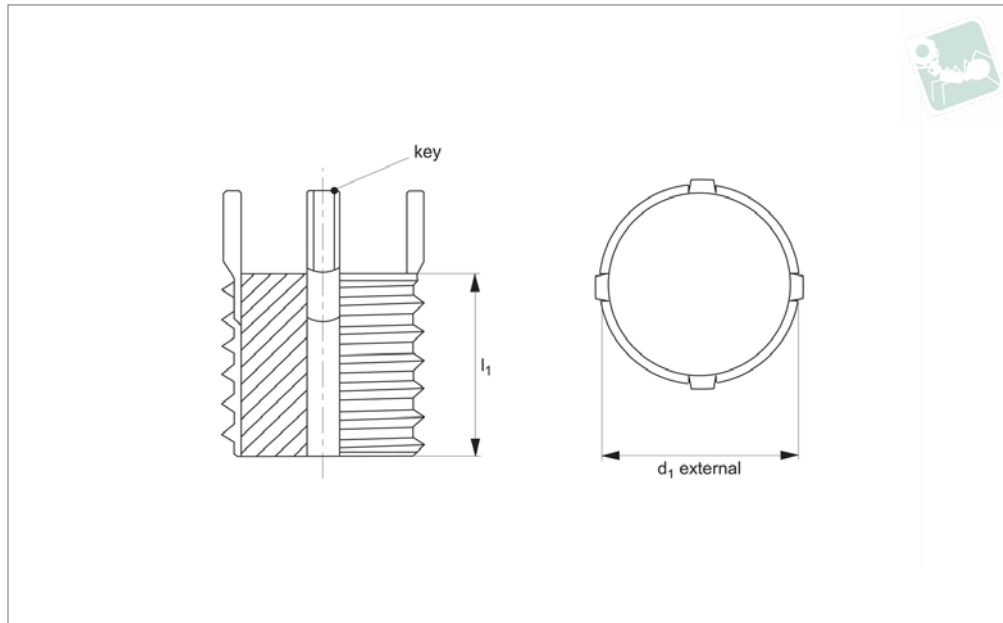

**TR1690**

THREADED INSERTS STAINLESS

## Material

Inserts: stainless steel (AISI 303) or equivalent. Passivated.

Keys: stainless steel (302 CRES) or equivalent. Passivated.

## Technical Notes

### General tolerances:

$\pm 0,25$  unless specified.

### Tap drill hole tolerances:

6,9 to 10,8 =  $+0,10/-0,025$ .

12,8 and over =  $+0,13/-0,025$ .

## Tips

Order installation tool separately, as identified by „Inst. tool ref.“ in table.

## Important Notes

Four locking keys on external threads M12 and over. Two locking keys on external

threads smaller than M12.

Installation (Inst.) drill size, countersink, thread tap and thread depth as specified in table.

Removal drill size and drill depth as specified in table.

External metric thread allows you to machine your internal thread.

Order No.	d <sub>1</sub>	Thread type d <sub>1</sub>	l <sub>1</sub>	Inst. tool ref. 22052	Inst. tap drill size	Inst. c'sink dia.	Inst. thread tap	Inst. thread tap depth	Removal drill size	Removal drill depth
TR1690.66421	M 8x1,25	Coarse	8	.W0210	6.9	8.3	M 8x1,25	9.5	5.50	4.0
TR1690.66422	M10x1,25	Fine	10	.W0220	8.8	10.3	M10x1,25	12.5	7.50	4.8
TR1690.66423	M12x1,25	Fine	12	.W0230	10.8	12.3	M12x1,25	14.5	9.50	4.8
TR1690.66424	M14x1,50	Fine	14	.W0240	12.8	14.3	M14x1,50	16.5	11.50	4.8
TR1690.66425	M16x1,50	Fine	16	.W0250	14.8	16.3	M16x1,50	18.5	13.50	4.8
TR1690.66426	M18x1,50	Fine	18	.W0260	16.8	18.3	M18x1,50	20.5	15.50	4.8
TR1690.66427	M20x1,50	Fine	20	.W0270	18.8	20.3	M20x1,50	22.5	17.50	4.8
TR1690.66428	M22x1,50	Fine	22	.W0280	20.5	22.3	M22x1,50	24.5	17.75	6.4
TR1690.66429	M24x1,50	Fine	24	.W0290	22.5	24.3	M24x1,50	26.5	19.75	6.4
TR1690.66430	M30x2,00	Non-Std	30	.W0300	28.0	30.3	M30x2,00	34.5	25.75	6.4
TR1690.66431	M32x2,00	Non-Std	32	.W0310	30.0	32.3	M32x2,00	36.5	27.75	6.4
TR1690.66432	M33x2,00	Non-Std	33	.W0320	31.0	33.3	M33x2,00	37.5	28.75	6.4



TR1696

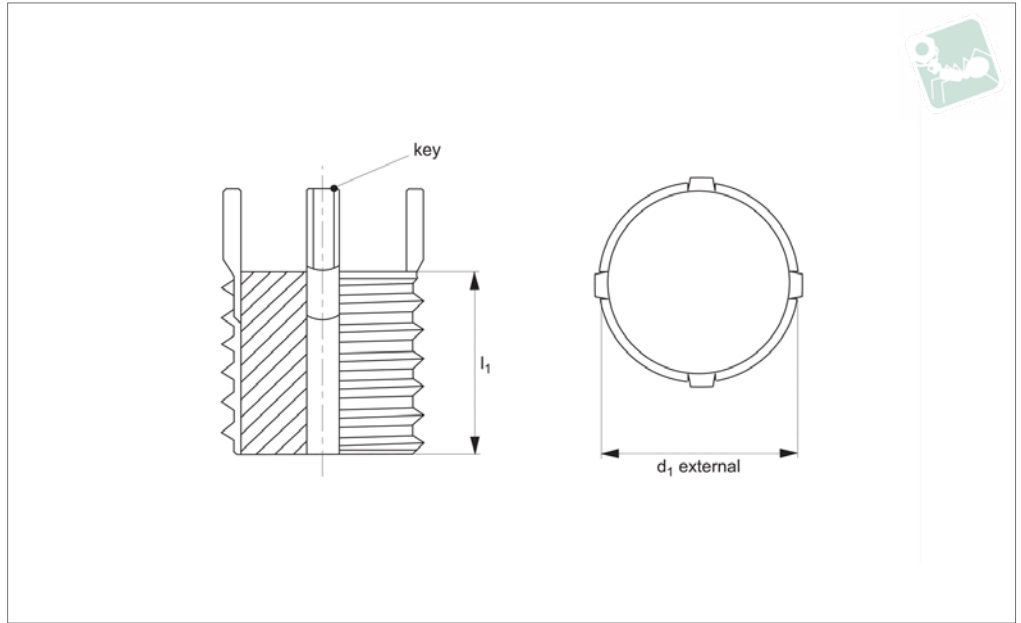

**Material**

Inserts: stainless steel (AISI 303) or equivalent. Passivated.  
 Keys: stainless steel (302 CRES) or equivalent. Passivated.

**Technical Notes**

**General tolerances:**

± 0,010" unless specified.

**Tap drill hole tolerances:**

0,234 to 0,500 = +0,004/-0,001".

0,500 and over = +0,005/-0,001".

**Tips**

Order installation tool separately, as identified by „Inst. tool ref.“ in table.

**Important Notes**

Four locking keys on external threads 7/16" and over. Two locking keys on external threads smaller than 7/16".  
 Installation (Inst.) drill size, countersink,

thread tap and thread depth as specified in table.

Removal drill size and drill depth as specified in table.

External inch thread allows you to machine your internal thread.

\*Unified special pitch thread.

**All dimensions in inches.**

Order No.	d <sub>1</sub> (mod.) tol. 2A	Thread type d <sub>1</sub>	l <sub>1</sub>	Inst. tool ref. 22050	Inst. tap drill size	Inst. c'sink dia. +0.010 - 0.000	Inst. thread tap tol. 2B	Inst. thread tap depth min.	Removal drill size	Removal drill depth
TR1696.66401	5/16"-18	UNC	0,31	.W0010	0,272	0,32	5/16"-18	0,37	7/32"	1/8"
TR1696.66402	3/8"-16	UNC	0,31	.W0020	0,332	0,38	3/8"-16	0,37	9/32"	1/8"
TR1696.66403	7/16"-14	UNC	0,37	.W0030	0,397	0,44	7/16"-14	0,43	11/32"	3/16"
TR1696.66404	1/2"-13	UNC	0,43	.W0040	0,453	0,51	1/2"-13	0,50	13/32"	3/16"
TR1696.66405	9/16"-12	UNC	0,50	.W0050	0,516	0,57	9/16"-12	0,56	15/32"	3/16"
TR1696.66406	5/8"-11	UNC	0,62	.W0060	0,578	0,63	5/8"-11	0,68	17/32"	3/16"
TR1696.66413	11/16"-11*	UNS	0,68	.W0065	0,641	0,70	11/16"-11*	0,75	19/32"	3/16"
TR1696.66407	3/4"-16	UNF	0,68	.W0070	0,703	0,76	3/4"-16	0,75	21/32"	3/16"
TR1696.66414	13/16"-16	UNF	0,81	.W0075	0,766	0,82	13/16"-16	0,94	23/32"	3/16"
TR1696.66408	7/8"-14	UNF	0,87	.W0080	0,828	0,88	7/8"-14	1,00	25/32"	5/16"
TR1696.66409	1"-12	UNF	0,87	.W0090	0,937	1,02	1"-12	1,00	27/32"	5/16"
TR1696.66410	1-1/8"-12	UNF	1,12	.W0100	1,062	1,14	1-1/8"-12	1,31	31/32"	5/16"
TR1696.66411	1-1/4"-12	UNF	1,25	.W0110	1,187	1,27	1-1/4"-12	1,44	1-3/32"	5/16"
TR1696.66412	1-3/8"-12	UNF	1,37	.W0120	1,312	1,39	1-3/8"-12	1,56	1-7/32"	5/16"