

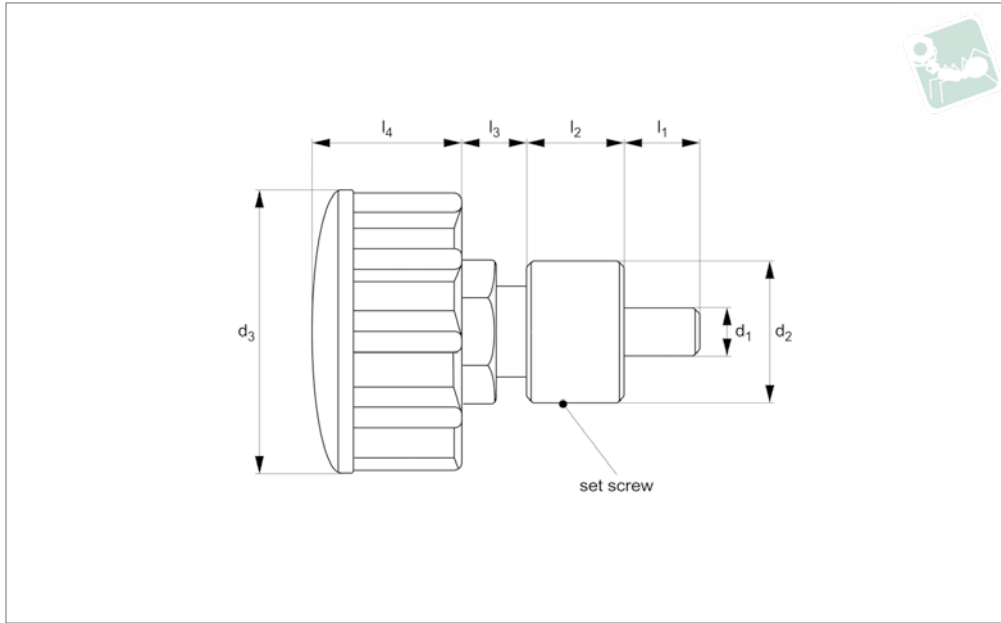

Spring Loaded Pin - Adjustable

inch - grip handle, weldable

Spring Loaded Pins



SL2516

SPRING LOADED PINS

Material

Housing: Steel, 12L15, un-plated.
 Plunger assembly: Steel, 1038, zinc plated.
 Handle: Thermoplastic

Technical Notes

Ideal for applications where there is a

variance in the part being held. Once the pin is engaged, turning the knob allows the pin to tighten down on the work piece or further extend the plunger into the locating hole.

The set screw on the housing allows you to

lock the plunger at a set depth for repeated operations and prevents the mechanism from coming out of the housing.

Order No.	d ₁ +0.05 -0.10	d ₂	l ₁	l ₂	l ₃	l ₄	d ₃	Adjustment
SL2516.025-143-C	6,35 (1/4")	28.5	14.3	19.0	12.7	28.58	57.1	15.8
SL2516.037-143-C	9,53 (3/8")	28.5	14.3	19.0	12.7	28.58	57.1	15.8
SL2516.050-143-C	12,7 (1/2")	28.5	14.3	19.0	12.7	28.58	57.1	15.8