

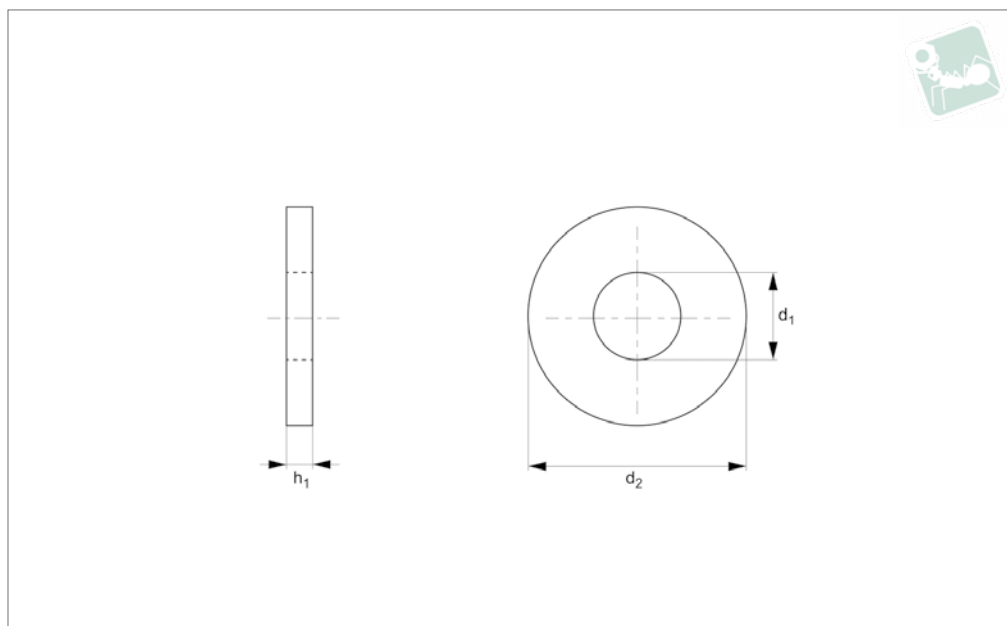

# A Plain Washers

Form A, DIN 125 A

Polypropylene



**P0330.N2**

POLYPROPYLENE

### Material

Polypropylene.

To DIN 125 A.

### Technical Notes

Polypropylene washers - form A.

Order No.	For thread	d <sub>1</sub>	d <sub>2</sub>	h	Material
P0330.020-N2	M 2	2.2	5	0.3	Polypropylene
P0330.022-N2	M2-5	2.2	5	0.3	Polypropylene
P0330.023-N2	M2,3	2.5	6	0.5	Polypropylene
P0330.025-N2	M2,5	2.7	6	0.5	Polypropylene
P0330.027-N2	M2,5	2.7	6	0.5	Polypropylene
P0330.030-N2	M 3	3.2	7	0.5	Polypropylene
P0330.032-N2	M3	3.2	7	0.5	Polypropylene
P0330.035-N2	M3,5	3.7	8	0.5	Polypropylene
P0330.037-N2	M3,5	3.7	8	0.5	Polypropylene
P0330.040-N2	M 4	4.3	9	0.8	Polypropylene
P0330.043-N2	M4-5	4.3	9	0.8	Polypropylene
P0330.050-N2	M 5	5.3	10	1.0	Polypropylene
P0330.053-N2	M5-3	5.3	10	1.0	Polypropylene
P0330.060-N2	M 6	6.4	12	1.6	Polypropylene
P0330.064-N2	M 6	6.4	12	1.6	Polypropylene
P0330.074-N2	M7-9	7.4	14	1.6	Polypropylene
P0330.080-N2	M 8	8.4	16	1.6	Polypropylene
P0330.084-N2	M8-5	8.4	16	1.6	Polypropylene
P0330.100-N2	M10	10.5	20	2.0	Polypropylene
P0330.250-N2	M24	25	44	4.0	Polypropylene



**P0500.N2**

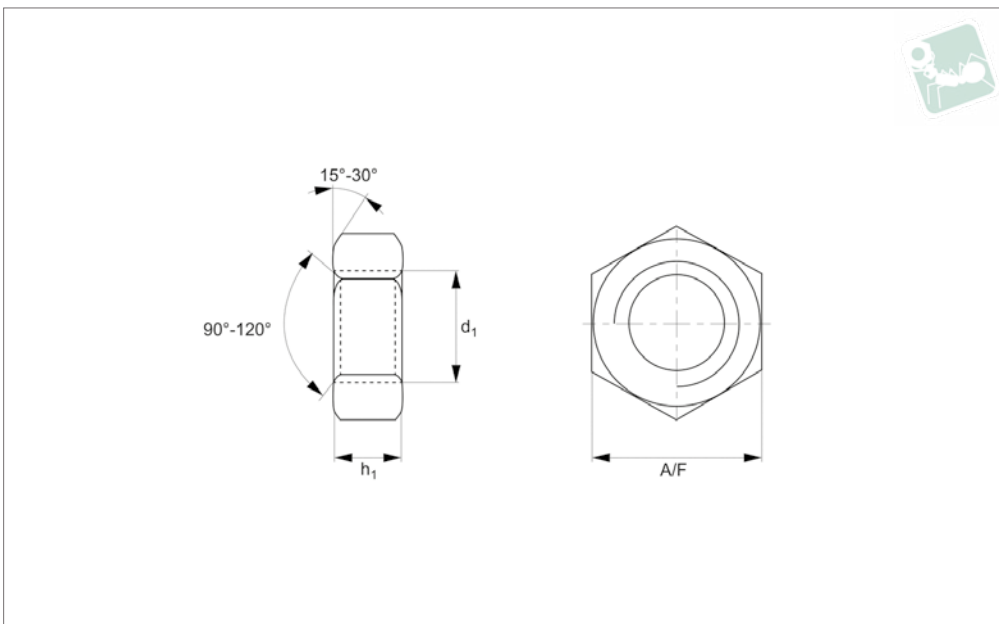

**Material**

Polypropylene.

To DIN 934. Standard metric coarse pitch threads.

**Technical Notes**

Polypropylene full nut

Order No.	d <sub>1</sub>	h <sub>1</sub> min.	A/F	Material	Finish
P0500.040	M 4	3.2	7.0	Polypropylene	unfinished
P0500.050	M 5	4.0	8.0	Polypropylene	unfinished
P0500.060	M 6	5.0	10	Polypropylene	unfinished
P0500.080	M 8	6.5	13	Polypropylene	unfinished
P0500.100	M10	8.0	17	Polypropylene	unfinished
P0500.120	M12	10	19	Polypropylene	unfinished
P0500.160	M16	13	24	Polypropylene	unfinished
P0500.200	M20	16	30	Polypropylene	unfinished
P0500.240	M24	19	36	Polypropylene	unfinished