

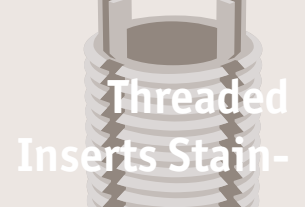

Threaded Insert MS/NAS - Mini - Inch

303 stainless steel - non-locking - MS/NAS grade



Threaded Inserts Stain-

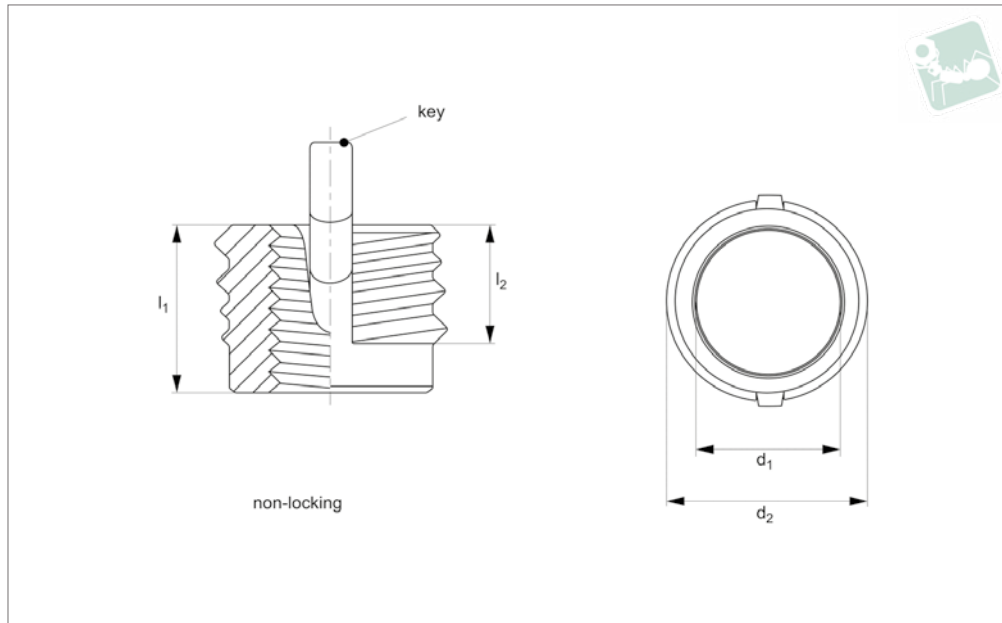

TR1650

THREADED INSERTS STAINLESS

Material

Inserts - 303 CRES.
Keys - 302 CRES.
Passivated. Dry film lubrication on self-locking inserts only.

Technical Notes

All dimensions in inches.
Internal threads: to SAE AS8879.
General tolerances -
+/- 0,010 unless specified.

Tap drill hole tolerances -
0,234 to 0,500 = +0,004/-0,001
0,500 and over = +0,005/-0,001
NL = Non-Locking type.

Tips

Order installation tool separately, as identified by „Inst. Tool ref.“ in table.

Important Notes

Four locking keys on internal threads 5/16

and over. Two locking keys on internal threads smaller than 5/16.
Installation (Inst.) drill size, counter sink, thread tap and thread depth as specified in table.
Removal (Rem.) drill size and drill depth as specified in table.
Perform to standards: MIL-I-45914A (MS51830)
* Modified minor dia.

Order No.	Type	d ₁ tol. 3B type	Thread d ₁	d ₂ tol. 2A type	Thread d ₂	l ₁	l ₂	C'sink hole size	Inst. tap drill size +0.00 3 - 0 - 0.001 0.000	Inst. thread tap depth min.	Inst. thread tap size tol. 6B	Inst. tool ref. TR1700	Removal drill size	Removal drill depth
TR1650.76283	NL	2-56	UNC	8-32	UNC	,120	,090	,166	,134	,140	8-32	.0830	#33	1/16
TR1650.76284	NL	4-40	UNC	10-32	UNF	,170	,125	,194	,161	,160	10-32	.0840	#29	3/32
TR1650.76285	NL	6-32	UNC	12-28	UNF	,170	,125	,220	,187	,160	12-28	.0850	#21	3/32
TR1650.76286	NL	8-32	UNC	1/4-28*	UNF	,220	,175	,255	,228	,210	1/4-28	.0860	#8	1/8