

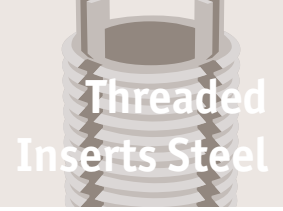

Threaded Insert MS/NAS - Mini - Inch

4140 steel - non-locking - MS/NAS grade



Threaded Inserts Steel

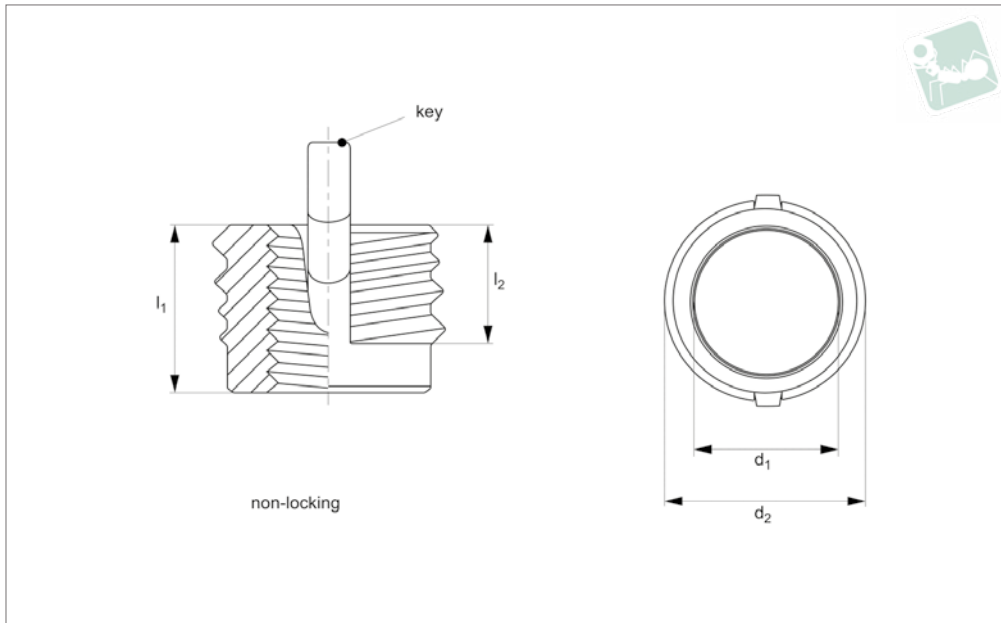

TR1660

THREADED INSERTS STEEL

Material

Inserts - 4140 alloy steel (160 KSI Min).
 Keys - 302 CRES.
 Cadmium plate (QQ-P-416 Type II, Cl. 2).
 Dry film lubrication on self-locking inserts only.

Technical Notes

All dimensions in inches.
 Internal threads: to SAE AS8879.
 General tolerances -
 +/- 0,010 unless specified.

Tap drill hole tolerances -

0,234 to 0,500 = +0,004/-0,001
 0,500 and over = +0,005/-0,001
NL = Non-Locking type.

Tips

Order installation tool separately, as identified by „Inst. Tool ref.“ in table.

Important Notes

Four locking keys on internal threads 5/16 and over. Two locking keys on internal

threads smaller than 5/16.

Installation (Inst.) drill size, counter sink, thread tap and thread depth as specified in table.

Removal (Rem.) drill size and drill depth as specified in table.

Perform to standards: MIL-I-45914A (MS51830)

* Modified minor dia.

Order No.	Type	d ₁ class 3B	Thread type d ₁	d ₂ class 2A	Thread type d ₂	l ₁	l ₂ thread length	Inst. c'sink hole size +0.010 - 0.000	Inst. tap drill size +0.003 -0.001	Inst. thread depth min.	Inst. tap thread tap size class 2B	Inst. tool ref. TR1700	Removal drill size	Removal drill depth
TR1660.80283	NL	2-56	UNC	8-32	UNC	,120	,90	,166	,134	,140	8-32	.0830	#33	1/16
TR1660.80284	NL	4-40	UNC	10-32	UNF	,170	,125	,194	,161	,160	10-32	.0840	#29	3/32
TR1660.80285	NL	6-32	UNC	12-28	UNF	,170	,125	,220	,187	,160	2-28	.0850	#21	3/32
TR1660.80286	NL	8-32	UNC	1/4-28*	UNF	,220	,175	,255	,228	,210	1/4-28	.0860	# 8	1/8