



Threaded Insert MS/NAS - H Duty - 4140 steel - self-locking - MS/NAS grade



TR1665

THREADED INSERTS STEEL

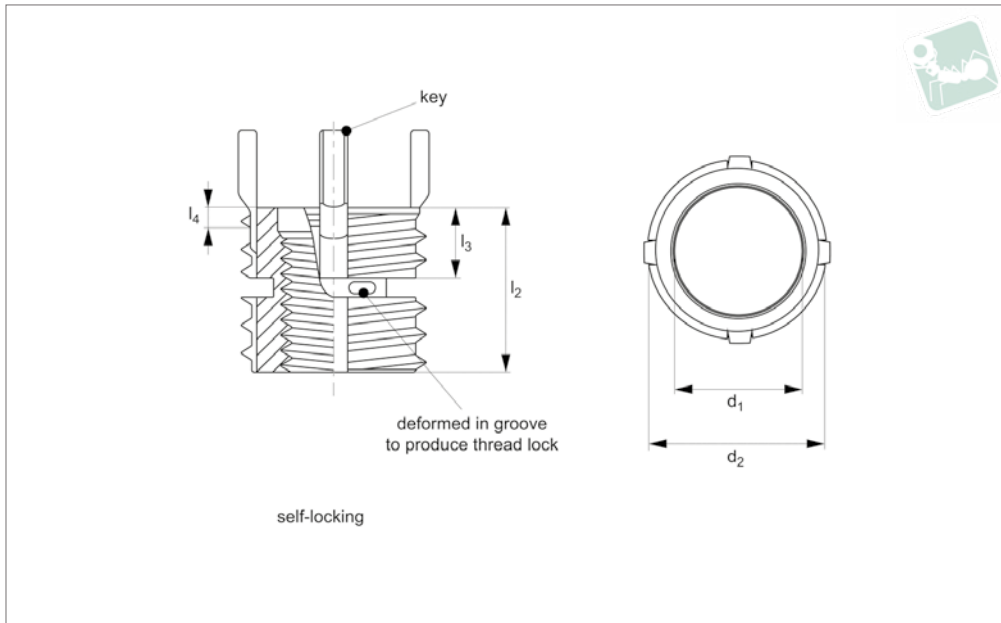

Material

Inserts - 4140 alloy steel (160 KSI Min).
Keys - 302 CRES.
Cadmium plate (QQ-P-416 Type II, Cl. 2).
Dry film lubrication on self-locking inserts only.

Technical Notes

All dimensions in inches.
Internal threads: to SAE AS8879.
General tolerances -
+/- 0,010 unless specified.

Tap drill hole tolerances -

0,234 to 0,500 = +0,004/-0,001
0,500 and over = +0,005/-0,001
SL = Self-Locking type, deliberate deformity in thread produces self-affect once installed (see technical diagram).

Tips

Order installation tool separately, as identified by „Inst. Tool ref.“ in table.

Important Notes

Four locking keys on internal threads 5/16 and over. Two locking keys on internal threads smaller than 5/16.
Installation (Inst.) drill size, counter sink, thread tap and thread depth as specified in table.
Removal (Rem.) drill size and drill depth as specified in table.
Perform to standards: MIL-I-45914A (MS51831 & NAS1395)

Order No.	Type	d ₁ class 3B	Thread type d ₁	d ₂ (mod.) class 2A	Thread type d ₂	l ₁	l ₃ ±0.0 30	l ₄ c'bore depth	Inst. c'sink hole size +0.010 - 0.000	Inst. tap drill size	Inst. thread tap depth min.	Inst. thread tap size class 2B	Inst. Removal tool ref. drill size	Removal drill depth
TR1665.81300	SL	8-32	UNC	5/16-18	UNF	,312	,22	,04	,323	,272	,37	5/16-18	.0000	7/32 1/8
TR1665.81301	SL	10-24	UNC	3/8-16	UNC	,312	,22	,07	,385	,332	,37	3/8-16	.0010	9/32 1/8
TR1665.81501	SL	10-32	UNF	3/8-16	UNC	,312	,22	,07	,385	,332	,37	3/8-16	.0011	9/32 1/8
TR1665.81302	SL	1/4-20	UNC	7/16-14	UNC	,375	,22	,07	,447	,397	,43	7/16-14	.0020	11/32 3/16
TR1665.81502	SL	1/4-28	UNF	7/16-14	UNC	,375	,22	,07	,447	,397	,43	7/16-14	.0021	11/32 3/16
TR1665.81303	SL	5/16-18	UNC	1/2-13	UNC	,437	,22	,07	,510	,453	,50	1/2-13	.0030	13/32 3/16
TR1665.81503	SL	5/16-24	UNF	1/2-13	UNC	,437	,22	,07	,510	,453	,50	1/2-13	.0031	13/32 3/16
TR1665.81304	SL	3/8-16	UNC	9/16-12	UNC	,500	,25	,07	,572	,516	,56	9/16-12	.0040	15/32 3/16
TR1665.81504	SL	3/8-24	UNF	9/16-12	UNC	,500	,25	,07	,572	,516	,56	9/16-12	.0041	15/32 3/16
TR1665.81305	SL	7/16-14	UNC	5/8-11	UNC	,625	,28	,10	,635	,578	,68	5/8-11	.0050	17/32 3/16
TR1665.81505	SL	7/16-20	UNF	5/8-11	UNC	,625	,28	,10	,635	,578	,68	5/8-11	.0051	17/32 3/16
TR1665.81306	SL	1/2-13	UNC	11/16-11NS	UNS	,688	,28	,10	,700	,641	,75	11/16-11NS	.0060	19/32 3/16
TR1665.81506	SL	1/2-20	UNF	11/16-11NS	UNS	,688	,28	,10	,700	,641	,75	11/16-11NS	.0061	19/32 3/16
TR1665.81307	SL	9/16-12	UNC	13/16-16	UN	,812	,32	,10	,822	,766	,94	13/16-16	.0070	23/32 3/16
TR1665.81507	SL	9/16-12	UNF	13/16-16	UN	,812	,32	,10	,885	,766	,94	13/16-16	.0071	23/32 3/16
TR1665.81308	SL	5/8-11	UNC	7/8-14	UNF	,875	,33	,10	,885	,828	1,00	7/8-14	.0080	25/32 3/16
TR1665.81508	SL	5/8-18	UNF	7/8-14	UNF	,875	,33	,10	,885	,828	1,00	7/8-14	.0081	25/32 3/16
TR1665.81309	SL	3/4-10	UNC	1-1/8-12	UNF	1,250	,49	,10	1,145	1,062	1,44	1-1/8-12	.0090	31/32 5/16
TR1665.81509	SL	3/4-16	UNF	1-1/8-12	UNF	1,250	,49	,10	1,145	1,062	1,44	1-1/8-12	.0091	31/32 5/16
TR1665.81310	SL	7/8-9	UNC	1-1/4-12	UNF	1,375	,49	,10	1,270	1,187	1,56	1-1/4-12	.0100	1-3/32 5/16
TR1665.81510	SL	7/8-14	UNF	1-1/4-12	UNF	1,375	,49	,10	1,270	1,187	1,56	1-1/4-12	.0101	1-3/32 5/16
TR1665.81311	SL	1-8	UNC	1-3/8-12	UNF	1,500	,55	,10	1,395	1,312	1,68	1-3/8-12	.0110	1-7/32 5/16



Order No.	Type	d ₁ class 3B	Thread type d ₁	d ₂ (mod.) class 2A	Thread type d ₂	l ₁	l ₃ ±0.0 30	l ₄ c'bore depth	Inst. c'sink hole size +0.010 - 0.000	Inst. tap drill size	Inst. thread tap depth min.	Inst. thread tap size class 2B	Inst. tool ref. TR1705	Removal drill size	Removal drill depth
TR1665.81511	SL	1-12	UNF	1-3/8-12	UNF	1,500	,55	,10	1,395	1,312	1,68	1-3/8-12	.0111	1-7/32	5/16