

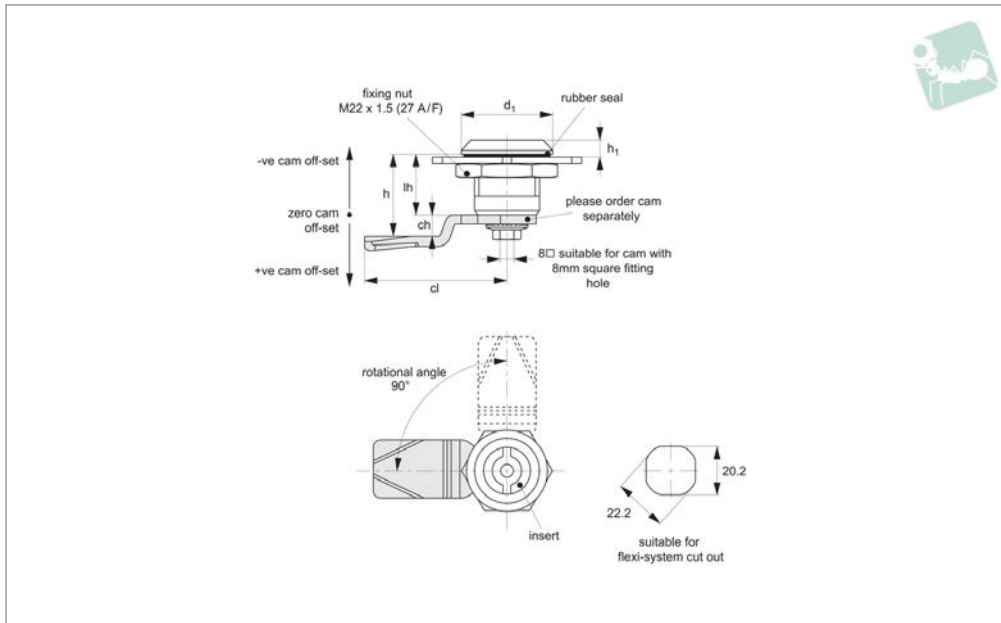

Cam Latches - Flexi-System

insert driver - fixed grip - zinc

Latches



CC0400

LATCHES

Material

Body & insert: die cast zinc. Finished in chrome plate or black powder coating. Insert fitted with O'ring to achieve IP54 rating. Internal spring provides 1.5mm torsion.

Supplied with: Nut: steel, zinc plated. Sealing washer: PU and rubber.

Not supplied: CAM nor KEY - order separately.

Technical Notes

Order cam and key separately.

Cams: see suitable cam CC0020, and CC0040. Select „without projection“ cam type.

Dimensions ch and cl relate to cam. Use formula to calculate ch (required cam off-set), and refer to cam selection chart;

ch = h - lh where;

ch = required cam off-set/height.

h = grip length (distance between inside of latch face and front of cam).

lh = body length of cam latch/lock to be used (see product table below).

Keys: see CC0010.

Rods & Guides: to achieve 3-point latching - CC0340, CC0350, CC0355.

Important Notes

Extended body version - CC0460.

Sold subject to pack quantity.

Order No.	Finish	Insert driver	d ₁	h ₁	lh
CC0400.H0010	Chrome Plated	Square 7	28	6	18
CC0400.H0020	Chrome Plated	Square 8	28	6	18
CC0400.H0040	Chrome Plated	Triangle 7	28	6	18
CC0400.H0050	Chrome Plated	Triangle 8	28	6	18
CC0400.H0060	Chrome Plated	3mm Double Bit	28	6	18
CC0400.H0070	Chrome Plated	4mm Double Bit	28	6	18
CC0400.H0080	Chrome Plated	Slotted (2x4)	28	6	18
CC0400.H0310	Black Coated	Square 7	28	6	18
CC0400.H0320	Black Coated	Square 8	28	6	18
CC0400.H0340	Black Coated	Triangle 7	28	6	18
CC0400.H0360	Black Coated	3mm Double Bit	28	6	18
CC0400.H0370	Black Coated	4mm Double Bit	28	6	18
CC0400.H0380	Black Coated	Slotted (2x4)	28	6	18