

Flat Washers Form A

A2 stainless

Stainless Steel

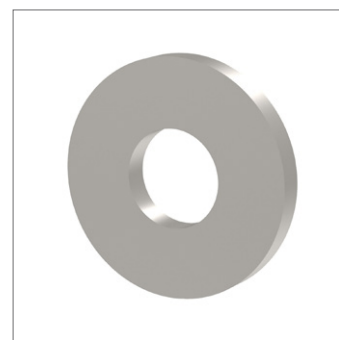
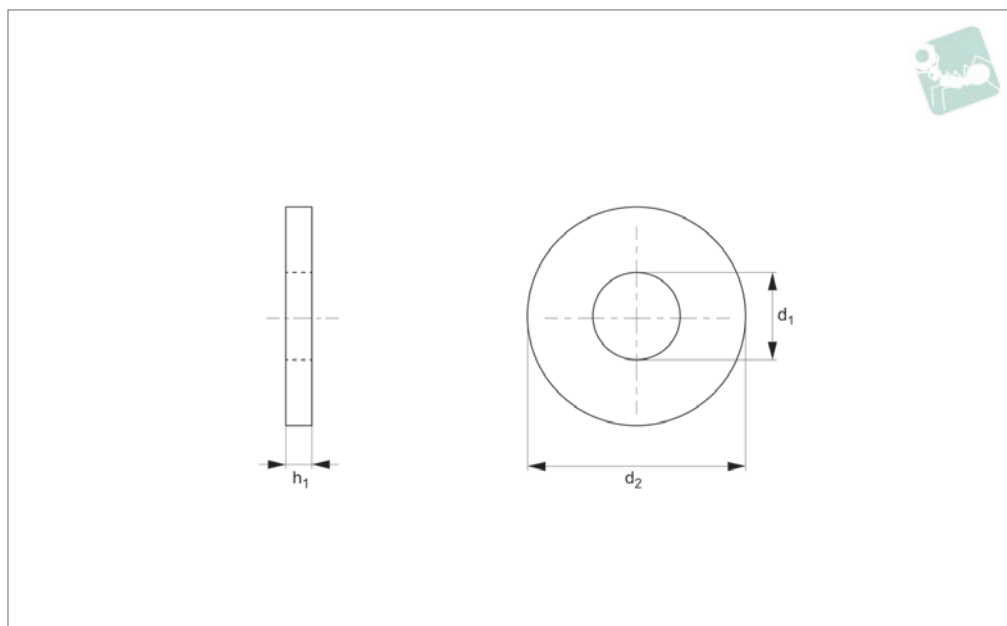

T0330.A2

STAINLESS STEEL

Material

Stainless steel (A2).

Technical Notes

To DIN 125 A.

Order No.	For thread	d ₁	d ₂	h ₁	Material
T0330.016-A2	M 1.6	1.7	4	0.3	A2 s/s
T0330.020-A2	M 2	2.2	5	0.3	A2 s/s
T0330.023-A2	M 2.3	2.5	6	0.5	A2 s/s
T0330.025-A2	M 2.5	2.7	6	0.5	A2 s/s
T0330.030-A2	M 3	3.2	7	0.5	A2 s/s
T0330.035-A2	M 3.5	3.7	8	0.5	A2 s/s
T0330.040-A2	M 4	4.3	9	0.8	A2 s/s
T0330.050-A2	M 5	5.3	10	1.0	A2 s/s
T0330.060-A2	M 6	6.4	12	1.6	A2 s/s
T0330.070-A2	M 7	7.4	14	1.6	A2 s/s
T0330.080-A2	M 8	8.4	16	1.6	A2 s/s
T0330.100-A2	M 10	10.5	20	2.0	A2 s/s
T0330.120-A2	M 12	13.0	24	2.5	A2 s/s
T0330.140-A2	M 14	15.0	28	2.5	A2 s/s
T0330.160-A2	M 16	17.0	30	3.0	A2 s/s
T0330.180-A2	M 18	19.0	34	3.0	A2 s/s
T0330.200-A2	M 20	21.0	37	3.0	A2 s/s
T0330.220-A2	M 22	23.0	39	3.0	A2 s/s
T0330.240-A2	M 24	25.0	44	4.0	A2 s/s
T0330.270-A2	M 27	28.0	50	4.0	A2 s/s
T0330.300-A2	M 30	31.0	56	4.0	A2 s/s